

**SYSTEM 600A  
SERVICE MANUAL**

# *CONTENTS*

<b>BILL OF MATERIALS</b>	2
<b>TEST PROCEDURE</b>	4
<i>Introductory remarks</i>	4
<i>Amplitude responses</i>	4
<i>THD measurements</i>	5
<i>Input level</i>	5
<i>Miscellaneous</i>	5
<i>Reference curves</i>	6
<b>DIAGRAMS</b>	8
<i>Components layout</i>	8
<i>Control switches wiring diagram</i>	9
<i>Power supply wiring diagram</i>	9
<i>Schematics</i>	10

## BILL OF MATERIALS

<i>Ref</i>	<i>Type</i>	<i>Spec</i>	<i>Spec2</i>	<i>Spec3</i>	<i>Spec4</i>
C1	Capacitor	10uF	20%	Electrolytic radial	45V
C2	Capacitor	10uF	20%	Electrolytic radial	45V
C3	Capacitor	10uF	20%	Electrolytic radial	25V
C4	Capacitor	10uF	20%	Electrolytic radial	25V
C5	Capacitor	4700uF	20%	Electrolytic radial	45V
C6	Capacitor	4700uF	20%	Electrolytic radial	45V
C7	Capacitor	100nF	5%	Metallised film	lp 5.08
C8	Capacitor	10uF	20%	Electrolytic radial	25V
C9	Capacitor	100nF	5%	Metallised film	lp 5.08
C10	Capacitor	10uF	20%	Electrolytic radial	25V
C11	Capacitor	220pF	5%	Metallised film	lp 5.08
C12	Capacitor	220pF	5%	Metallised film	lp 5.08
C13	Capacitor	100nF	5%	Metallised film	lp 5.08
C14	Capacitor	100nF	5%	Metallised film	lp 5.08
C15	Capacitor	1nF	5%	Metallised film	lp 5.08
C16	Capacitor	1nF	5%	Metallised film	lp 5.08
C17	Capacitor	1nF	5%	Metallised film	lp 5.08
C18	Capacitor	1nF	5%	Metallised film	lp 5.08
C19	Capacitor	220pF	5%	Metallised film	lp 5.08
C20	Capacitor	1nF	5%	Metallised film	lp 5.08
C21	Capacitor	22uF	20%	Electrolytic radial	16V
C22	Capacitor	100nF	5%	Metallised film	lp 5.08
C23	Capacitor	22uF	20%	Electrolytic radial	45V
C24	Capacitor	100nF	5%	Metallised film	lp 5.08
C26	Capacitor	1.5nF	5%	Metallised film	lp 5.08
C27	Capacitor	15nF	5%	Metallised film	lp 5.08
C28	Capacitor	2.2nF	5%	Metallised film	lp 5.08
C29	Capacitor	10nF	5%	Metallised film	lp 5.08
C30	Capacitor	2.2nF	5%	Metallised film	lp 5.08
C31	Capacitor	100nF	5%	Metallised film	lp 5.08
C32	Capacitor	470nF	5%	Metallised film	lp 5.08
C33	Capacitor	100nF	5%	Metallised film	lp 5.08
C34	Capacitor	22uF	20%	Electrolytic radial	45V
C35	Capacitor	22uF	20%	Electrolytic radial	16V
C36	Capacitor	100nF	5%	Metallised film	lp 5.08
D1	Diode	1N4148			
DB1	Bridge rectifier	4A		Vrrm = 100V	KBU402G
IC1	Dual OP amp	OP275GP			
IC2	Quad Op amp	TL074CN			
IC3	Quad Op amp	TL074CN			
IC4	Power Op amp	TDA7294V			
IC5	Power Op amp	TDA7294V			
J0	Mains socket	IEC type		flange fixing	with 20x5 fuse
J1	Connector			NCJ6FKH	
J2	Header	8w - 2rows		HE14	
L1	Resistor	0 Ohms			
L2	Resistor	0 Ohms			
L3	Resistor	0 Ohms			
L4	Resistor	0 Ohms			
L5	Resistor	0 Ohms			
L6	Resistor	0 Ohms			

<i>Ref</i>	<i>Type</i>	<i>Spec</i>	<i>Spec2</i>	<i>Spec3</i>	<i>Spec4</i>
LED1	LED	5mm	Blue	standard	
R1	Resistor	10k	1%	Metal film	0.25W
R2	Resistor	20k	1%	Metal film	0.25W
R3	Resistor	10k	1%	Metal film	0.25W
R4	Resistor	30k	1%	Metal film	0.25W
R5	Resistor	200R	1%	Metal film	0.25W
R6	Resistor	2k2	1%	Metal film	0.25W
R7	Resistor	200R	1%	Metal film	0.25W
R8	Resistor	1k3	1%	Metal film	0.25W
R9	Resistor	470R	1%	Metal film	0.25W
R10	Resistor	15k	1%	Metal film	0.25W
R11	Resistor	47k	1%	Metal film	0.25W
R12	Resistor	100k	1%	Metal film	0.25W
R13	Resistor	15k	1%	Metal film	0.25W
R14	Resistor	6k8	1%	Metal film	0.25W
R15	Resistor	8k2	1%	Metal film	0.25W
R16	Resistor	220k	1%	Metal film	0.25W
R17	Resistor	8k2	1%	Metal film	0.25W
R18	Resistor	200k	1%	Metal film	0.25W
R19	Resistor	5k6	1%	Metal film	0.25W
R20	Resistor	16k	1%	Metal film	0.25W
R21	Resistor	1k	1%	Metal film	0.25W
R22	Resistor	16k	1%	Metal film	0.25W
R23	Resistor	4k7	1%	Metal film	0.25W
R24	Resistor	2k	1%	Metal film	0.25W
R25	Resistor	68k	1%	Metal film	0.25W
R26	Resistor	n/f			
R27	Resistor	15k	1%	Metal film	0.25W
R28	Resistor	10k	1%	Metal film	0.25W
R29	Resistor	18k	1%	Metal film	0.25W
R30	Resistor	18k	1%	Metal film	0.25W
R31	Resistor	18k	1%	Metal film	0.25W
R32	Resistor	1k5	1%	Metal film	0.25W
R33	Resistor	27k	1%	Metal film	0.25W
R34	Resistor	1k	1%	Metal film	0.25W
R35	Resistor	27k	1%	Metal film	0.25W
R36	Resistor	12k	1%	Metal film	0.25W
R37	Resistor	13k	1%	Metal film	0.25W
R38	Resistor	10k	1%	Metal film	0.25W
R39	Resistor	13k	1%	Metal film	0.25W
R40	Resistor	2k2	1%	Metal film	0.25W
SW1	Toggle switch	SPDT		7101SHZQ	
SW2	Toggle switch	SPDT		7101SHZQ	
SW3	Toggle switch	SPDT cent. off		7103SHZQ	
SW0A	Rocker switch	DPST		Snap fit	
SW0B	Rotary switch	DPDT		Voltage selector	
T1	Transformer	Toroidal		Dual primary	Tannoy TI-65220
U1	Voltage regulator	LM317LZ			
U2	Voltage regulator	LM337LZ			

# TEST PROCEDURE

## ***Introductory remarks***

- the input should be connected to a balanced generator, pin 2 = hot, pin 3 = cold, pin 1 = ground
- the measured signal should be taken alternatively at the LF and HF outputs, with a balanced connection to the analyser : LF output is between the brown (+) and blue (-) leads, HF output between yellow (+) and green (-) leads. Note that the minus return to ground.
- both LF and HF outputs should be loaded with an 8 Ohm power resistor (rating  $\geq 25$  Watts).
- there are 3 switches which affect the responses. Unless stated otherwise, they are intended to be in their “normal” position, defined as :
  - \* INPUT LEVEL : + 4dBu
  - \* LF CONTROL : Half space
  - \* HF CONTROL : 0
- on the attached curves, the Y co-ordinate is in dB that is, it is an actual gain. Therefore it is also the value one would get (in dBV) at the output if 1Vrms is applied at the input.

## ***Amplitude responses***

### 1.1 LF channel (curve 1)

<b><i>Parameters</i></b>	<b><i>Values</i></b>
Start / stop frequencies	20 Hz - 5 kHz
Input level	1 Vrms
Number of points	$\geq 40$
Acceptance limits	+/- 0.7 dB from 50 Hz to 1500 Hz +/- 1.2 dB elsewhere

### 1.2 LF channel, LF CONTOUR set to “Free space” (curve 2)

<b><i>Parameters</i></b>	<b><i>Values</i></b>
same as test 1.1	

### 1.3 HF channel (see curve 3)

<b><i>Parameters</i></b>	<b><i>Values</i></b>
Start / stop frequencies	600 Hz - 20000 Hz
Input level	1 Vrms
Number of points	$\geq 40$
Acceptance limits	+/- 0.7 dB from 1500 Hz to 7000 Hz +/- 1.2 dB elsewhere

1.4 HF channel, HF CONTROL set to "+2" (curve 4)

same as 1.3

1.5 HF channel, HF CONTROL set to "-2" (curve 5)

same as 1.3

### ***THD measurements***

2.1 LF channel

<b><i>Parameters</i></b>	<b><i>Values</i></b>
Test frequencies	100 Hz, 800 Hz
Input level	1 Vrms
Acceptance limits	0.1 %

2.2 HF channel

<b><i>Parameters</i></b>	<b><i>Values</i></b>
Test frequencies	2 kHz, 10 kHz
Input level	1 Vrms
Acceptance limits	0.1 %

### ***Input level***

Taking a single test frequency (e.g. 500 Hz), the difference in level at the LF output between the two positions of the switch should be 11.7 dB +/- 0.5 dB. Note that for this test the input level should be reduced to 0.3 Vrms.

### ***Miscellaneous***

Visual check of the LED.

## Reference curves

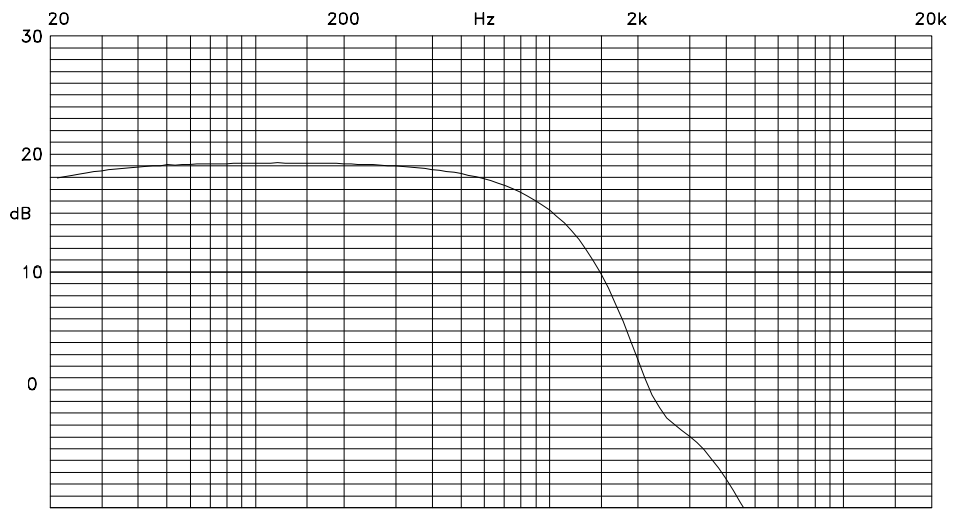

**Curve 1 LF channel (Half space)**

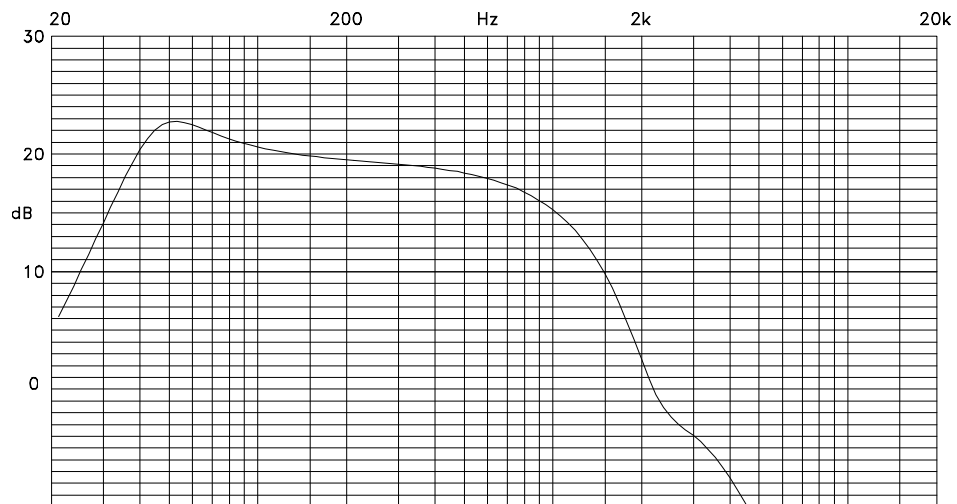

**Curve 2 LF channel (Free space)**

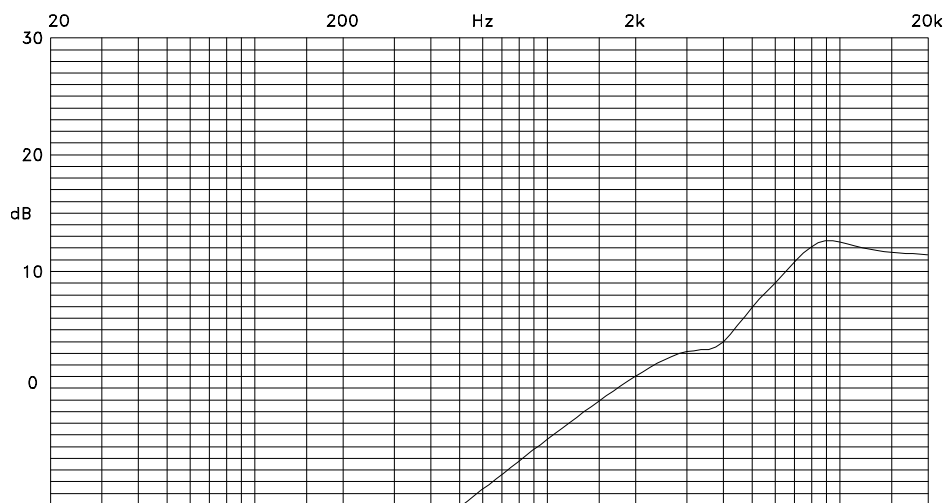

**Curve 3. HF channel (HF control 0 dB)**

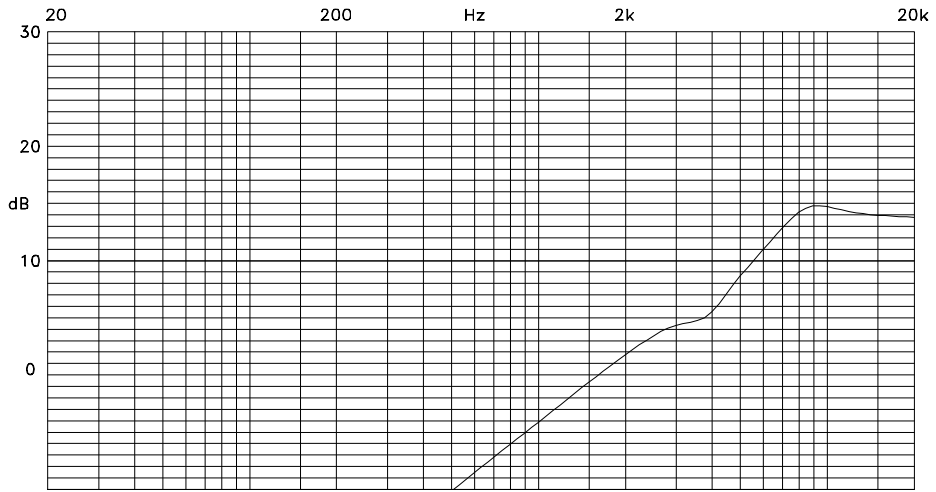

**Curve 4 HF channel (HF control +2)**

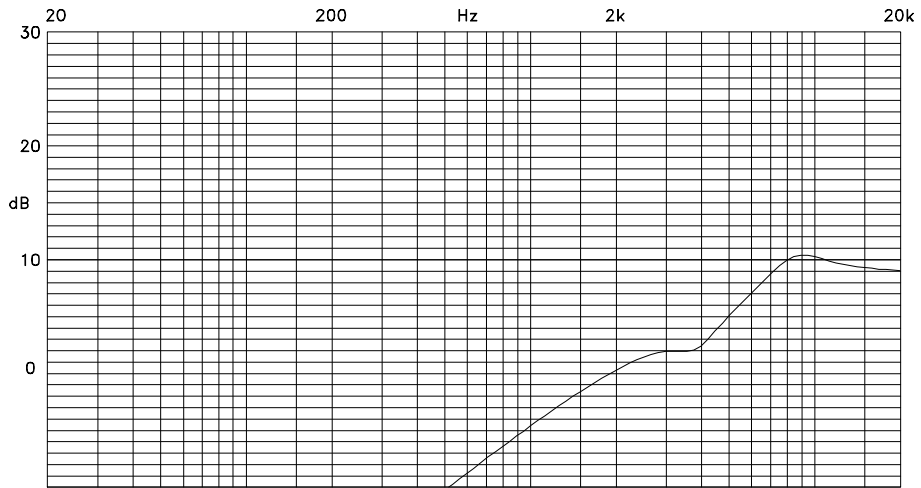

**Curve 5 HF channel (HF control - 2dB)**

# DIAGRAMS

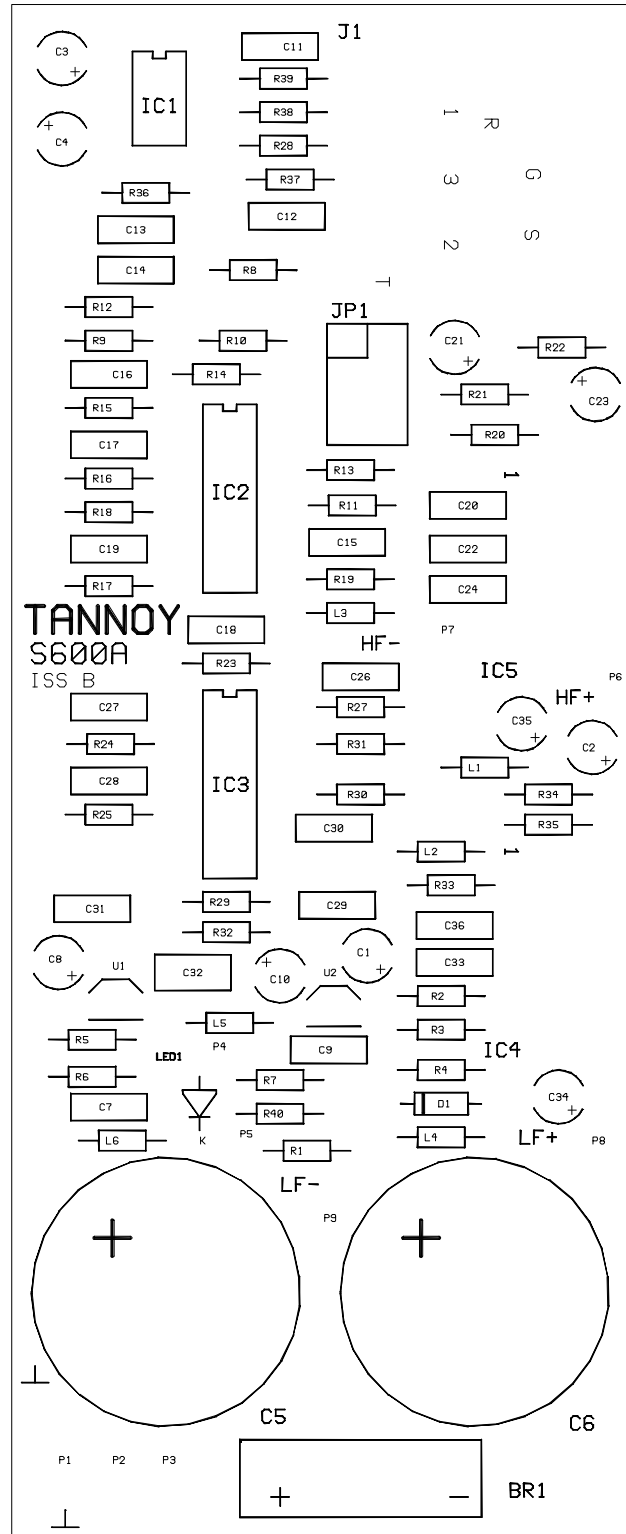

Figure 1. Components layout

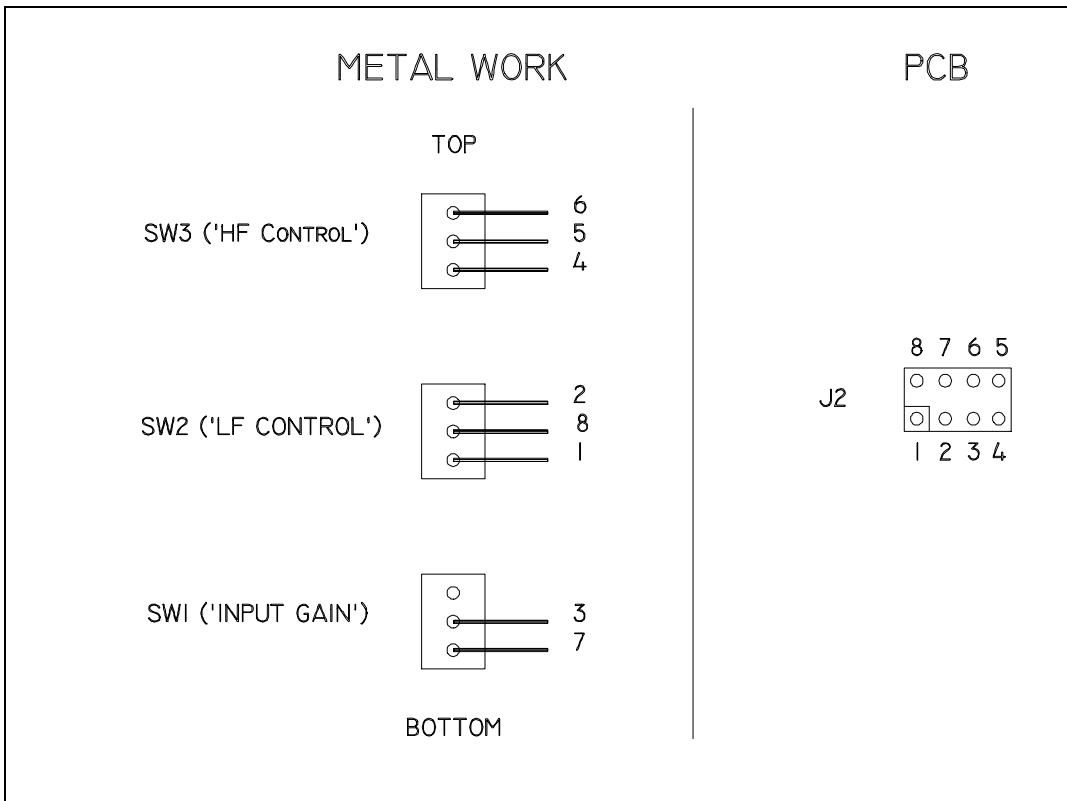

Figure 2. Control switches wiring diagram

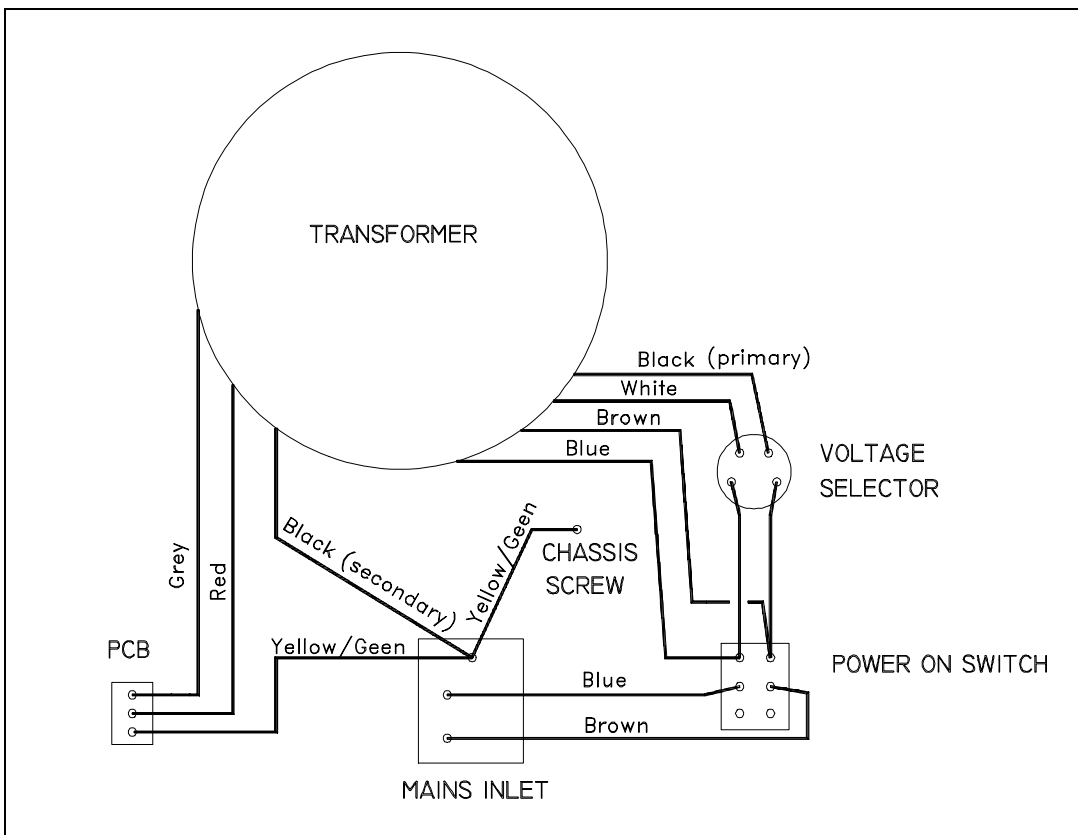
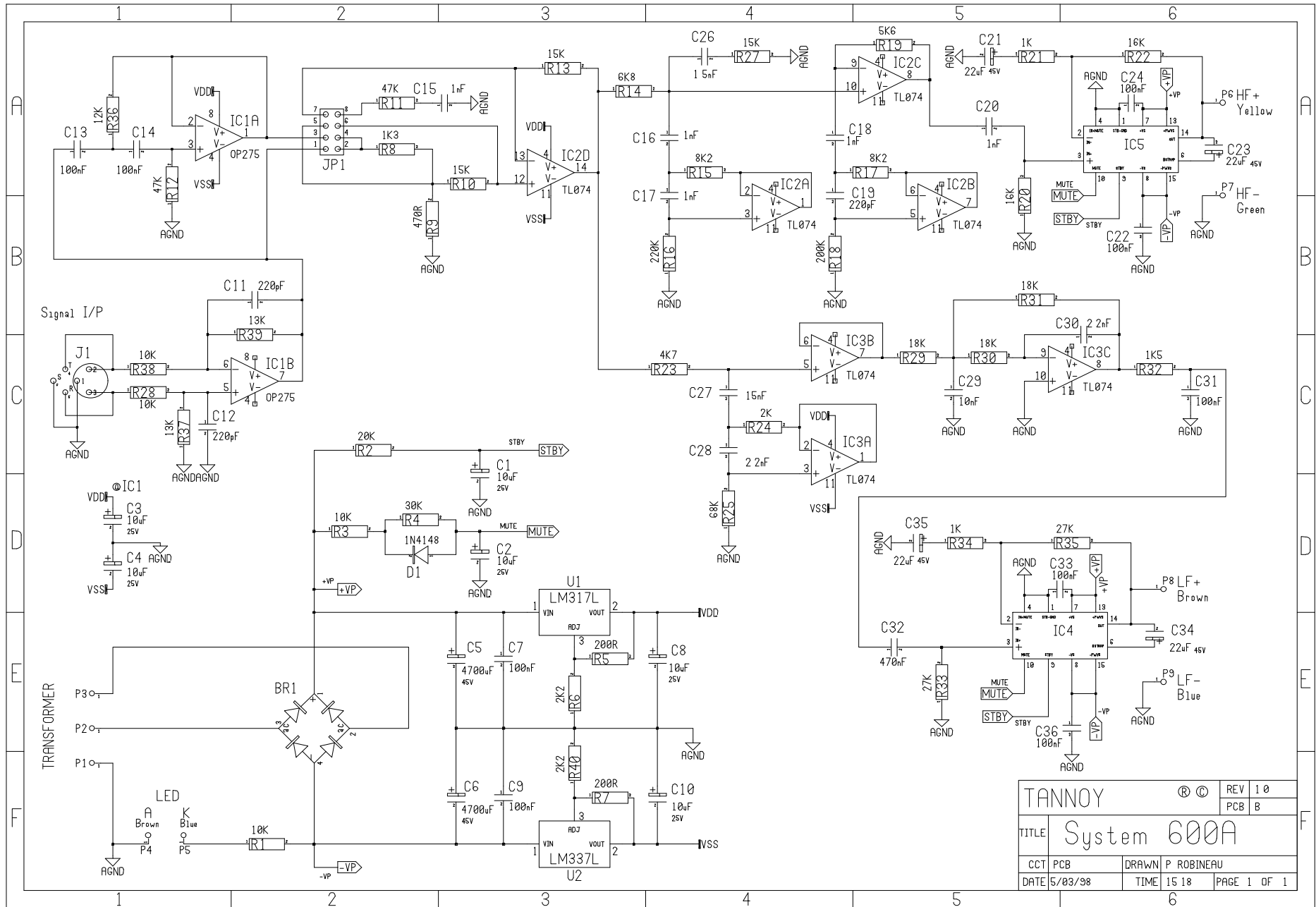

Figure 3 Power supply wiring diagram





---

**Tannoy Loudspeakers are manufactured  
in Great Britain by :**

**Tannoy Ltd, Rosehall Industrial Estate, Coatbridge,  
Strathclyde, ML5 4TF, SCOTLAND  
Telephone: +44 (0)1236 420199 Fax: +44 (0)1236 428230**

TGI/Tannoy, 300 Gage Avenue, Kitchener, Ontario, CANADA, N2M 2C8  
Telephone: (519) 745 1158 Fax: (519) 745 2364

Tannoy Nederland BV, Anthonetta Kuijlstraat 19, 3066 GS Rotterdam, THE NETHERLANDS  
Telephone: (010) 2860554 Fax: (010) 2860431