

LUXMAN

AM/FM STEREO TUNER

WL550

SERVICE MANUAL

CIRCUIT DESCRIPTION

GENERAL

LUX WL550 is all solid state high-fidelity AM/FM stereo transistorized radio tuner. The circuitry used in this instrument is mostly integrated in 2 printed circuit boards. The FM tuner circuit board is completely shielded, and mounted on a 7-gang AM/FM tuning capacitor. Conventional wiring is used in mains selector, function switch sections and front and rear panel assembly parts.

FM TUNER FL516U BOARD

The RF-amplifier is designed to provide stable amplification, sharp selectivity at FM broadcast frequencies, and an optimum noise figure. The dual-gate junction FET is ideally suited for this job as it has superior cross-modulation performance as a function of AGC, and in addition has a very wide dynamic range. The stage employs dual-gate FET (3SK30) in a common-source configuration, and the RF signal and gain control signal are applied to gate NO.1 and gate NO.2 is grounded to earth potential. The double-tuned coupling is employed between RF and mixer stages to provide sharp selectivity. The mixer stage is designed to minimize the spurious responses and noise figure. The 2SC535 mixer transistor operates in the common emitter configuration with the RF signal and local oscillator signal are applied to the base terminal. The 10.7MHz IF output from the mixer is coupled to the first IF-amplifier stage by means of a double-tuned transformer T101. The SE3001 local oscillator transistor is operated in a common-collector circuit that generates a clean oscillator wave form to minimize the generation of spurious responses. The oscillator signal is coupled to the mixer by means of 1-picofarad capacitor, which isolates the tuned circuit of the oscillator from the input circuit of the mixer and this minimizes the possibility of oscillator instabilities as a result of "pulling".

IF-AMPLIFIER

The IF-amplifier uses two 2SC381 transistors, a μ pc555A integrated-circuit, and a TA7061P integrated-circuit. The selectivity stages are two ceramic filters, and a double tuned transformer. The μ pc555A integrated-circuit is a basic differential amplifier with constant-current transistor that provides 31-dB power gain. The TA7061P integrated-circuit consists of three differential amplifier in cascade. Each differential pair is isolated from the succeeding pair by a common-collector stage used as a buffer. The amplifier section provides 68-dB total power gain at 10.7 MHz, and features an output stage with exceptionally good limiting characteristics because of its transistor constant-current sink. The selectivity of this IF section is determined by the ceramic filters in the interstage amplifying paths.

The filters provide extremely sharp skirt selectivity and flat response inside the pass band. Detector transformer T203 and matched pair diodes D206, D207 form a balanced ratio detector, that transforms the frequency-modulated signal into an audio signal. The detector transformer T203 is designed to provide the wide peak-to-peak separation required for good multiplex operation. A null-type meter connected across the output of the ratio detector is used as a center tuning indicator. The IF signal for AGC is extracted from the base of Q202 to drive Q205. Q205 acts as an IF-amplifier to drive the voltage doubler D201, D202. This DC voltage is applied to Q101 on the FM TUNER as an AGC BIAS. The IF signal, extracted from the output of the T202, is amplified by Q206 buffer amplifier to drive the rectifier D204 and associated components. This DC voltage drives a signal meter and muting circuits. The amplitude component of IF signal, extracted from the output of the second ceramic filter F202 is rectified by D203. The AC component of this signal feeds to the multi-path check terminal.

MULTIPLEX DEMODULATOR

The μ pc554C is a monolithic FM stereo multiplex decoder system constructed on a single silicon chip using the planar epitaxial process. This integrated circuit accomplishes the demodulation of a stereo multiplex signal into the right and left audio channels while inherently suppressing SCA frequency component. Internal provision is made for inter-station audio muting, stereo/mono mode switching and driving an external stereo mode indicator lamp. Stereo demodulation in the μ pc554C is achieved by a fully balanced differential synchronous demodulator (Figure). In this demodulator, the composite stereo signal is fed to the base of transistor Q11. The resulting AC current which flows in the collector of Q11 is then switched at 38KHz rate by the differential pair Q7 and Q8. The amplitude of the 38KHz switching signal is large enough to instantaneously gate the AC current alternately to the left and right audio channels. If the 38KHz gating signal is properly phased with respect to the composite stereo signal, this process will separate the stereo signal into its left and right audio components. A second differential stage (Q9, Q10 and Q13) is added to the stereo demodulator for two reasons. First, the 38KHz also switches the DC current flowing in the collector of Q11 resulting in a large undesired 38KHz voltage in both channels. By gating the DC current in Q13 and adding the resulting signals in phase opposition to those from Q12, these 38KHz components are cancelled. More importantly, however, the second differential stage provides improved stereo separation. With a single differential demodulator stage, the theoretical stereo separation

ration is limited to 13 dB due to the crosstalk inherent in the half-wave demodulation process. If a portion of the desired output is inverted and added to the crosstalk signal, however, this crosstalk component can be effectively cancelled resulting in stereo separations that are typically 45 dB. To demodulate the stereo signal, the 38KHz switching voltage must be reconstructed from the 19KHz pilot subcarrier. In the $\mu\text{pc}554\text{C}$ this is accomplished by frequency doubling the 19KHz pilot. First, the pilot subcarrier is filtered from the composite stereo signal by 19KHz tuned circuit T204 and T206 and then amplified by the Darlington pair Q19 Q20. This amplified 19KHz pilot causes the composite PNP pair Q14 Q15 to conduct during negative swings. The resultant 19KHz pulses are then used to drive the 38KHz amplifier Q16. A 38KHz tuned circuit T205 at the collector of Q16 filters the 38KHz component from these pulses and also provides a DC path to insure balanced bias conditions at the demodulator transistor bases. The resultant DC voltage which appears at the emitter of Q16 when a 19KHz subcarrier is present, is used to drive the stereo indicator lamp circuits. Transistors Q30, Q31 and Q32 make up the Schmitt circuit which is set in the monaural mode when the external control voltage approaches zero. Under this condition, Q30 is biased off and Q31 and Q32 are conducting. When turned on, transistor Q30 saturates and prevents any 19KHz signal from reaching the 19KHz amplifier, Q19 Q20, by shunting the AC to ground. Now, when the DC control voltage rises to approximately to 0.6V, there is sufficient bias to turn on Q30. Transistor Q30 then fully gets saturated, removing bias from Q28 and allowing the 19KHz signal to be amplified. This sets the IC decoder in the stereo mode. IC multiplex decoders contain circuitry which will allow the audio signals to either pass normally or be attenuated by about 55 dB in response to an external DC control voltage applied to pin 5 of the IC. The audio mute switching is achieved with a Schmitt trigger construction of transistor Q21, Q22 and Q23 whose operation are similar to those of the stereo monaural circuit previously described. The $\mu\text{pc}554\text{C}$ contains circuitry consisting of a Schmitt trigger switch and power NPN stage for driving a high current stereo indicator lamp. The lamp driver switch (Q27 Q28 Q29) is activated by the detected 19KHz. When sufficient 19KHz pilot is present the Schmitt trigger will be turned on by the resultant DC at pin 14. When the Schmitt circuit is on, it allows the power NPN stage (Q25, Q26) to be saturated placing the full supply voltage across the stereo lamp.

FM MUTING AND ASSOCIATED CIRCUITS

The DC voltage, which is rectified by D204, drives Q213. When interstation noise or insufficient signal is available, the cumulate voltage, consisting of the preset forward bias

and the positive voltage developed by the rectifier circuit is insufficient to make Q213 conduct. And Q214 conducts on saturation, therefore muting driver transistor Q215 is cut-off. In this case the signal is muted at Q207. The presence of an acceptable signal level makes the base voltage to Q213 large enough to overcome the sustain voltage on Q213. Then Q213, Q214, Q215 and Q207 are driven to alternate states. The forward bias to Q213 is fixed by VR201.

DC output of the 10.7MHz ratio detector is coupled to the base of Q401 and Q412 through D401. When there is zero DC at the ratio detector (i.e., the point of perfect tuning or the point of interstation), Q401 cuts off and Q402 conducts on saturation, therefore transistor Q403 cuts off. As a result, one gate of wired OR circuit turns on so Q215 drives only the other signal strength transistor Q214. When there is positive DC voltage at the ratio detector, Q401 conducts on saturation and Q402 cuts off, therefore wired OR transistor Q403 is gated off. While the appearance of negative DC at the ratio detector, the base of Q402 is biased to negative voltage through diode D401, since Q402 cuts off and the wired OR Q403 is gated off.

Audio muting is controlled by three gate circuits, that is, signal strength gate Q214, center tuning gate Q403 and stereo gate Q216. Signal strength gate and center tuning gate are constructed by wired OR circuit and drive buffer amplifier Q215. Audio signal is muted at IC Q207 which is controlled by DC voltage at pin 5.

This DC voltage is selected by the function switch for "FM auto stereo", "mono" and "stereo only". When the muting switch is in on and the function switch in "FM stereo" or "mono", Q215 drives directly Q207. When the function switch is set to "stereo only" Q207 is driven by Q216 which is connected to the stereo indicator. The stereo indicator will operate only when a strong signal is received and the station transmits a stereo program, as mono-stereo mode is controlled by an external DC voltage (Q215 emitter voltage which is equal to the wired OR output signal) applied to pin 4 of Q207. Thus the tuner is muted except when a strong stereo signal is received.

AM TUNER

A ferrite-rod antenna assembly which includes the tuned antenna transformer L1 selects the RF-signal from the desired radio broadcast station and couples it to the base of the Q208 RF-amplifier transistor. In the converter stage, the RF-signal from the RF-amplifier is mixed with a local oscillator signal to produce a signal at the receiver intermediate frequency of 455KHz. The antenna circuit, RF-amplifier, and converter are tuned together by means of mechanically ganged variable capacitor so that the local oscillator frequency is always 455KHz, and signal from the

converter stage is amplified by two IF-amplifier stages. The amplified IF-signal is then demodulated in the detector circuit consisting of D211 and associated components. D403 and associated components develop a negative voltage proportional to the input RF signal. This voltage is applied to the base of the first IF-amplifier Q210 as AGC bias. Since Q403 acts DC-amplifier, RF-amplifier transistor Q208 is controlled by the collector current of Q210. VR202 is used to adjust the Q208 collector current for set-point.

AM MUTING

The DC output of D211 is amplified by Q213, Q214 and Q215 amplifiers. When interstation noise or insufficient signal is available, the DC output of D211 is insufficient to make Q213 conduction. In this case, Q213 cuts off, Q214 conducts on saturation and Q215 cuts off. Therefore

Q212 cuts off and the audio signal is completely muted. When the tuner receives the sufficient signal, which is enough to turn on Q213, Q214 is off and Q215 is on. In this case Q212 is properly biased and allows the audio signal to pass to the succeeding circuit.

POWER SUPPLY

A regulated power supply provides a stable DC voltage which is applied to all circuit boards. The DC output from the rectifier is filtered and applied to the series regulator Q217. Transistor Q219 compares a sample of the output voltage with a reference voltage supplied by the zener diode in Q207. A change in output voltage, detected by Q219, results in a change in conduction of Q218 and Q217 that offsets the original voltage shift.

BLOCK DIAGRAM

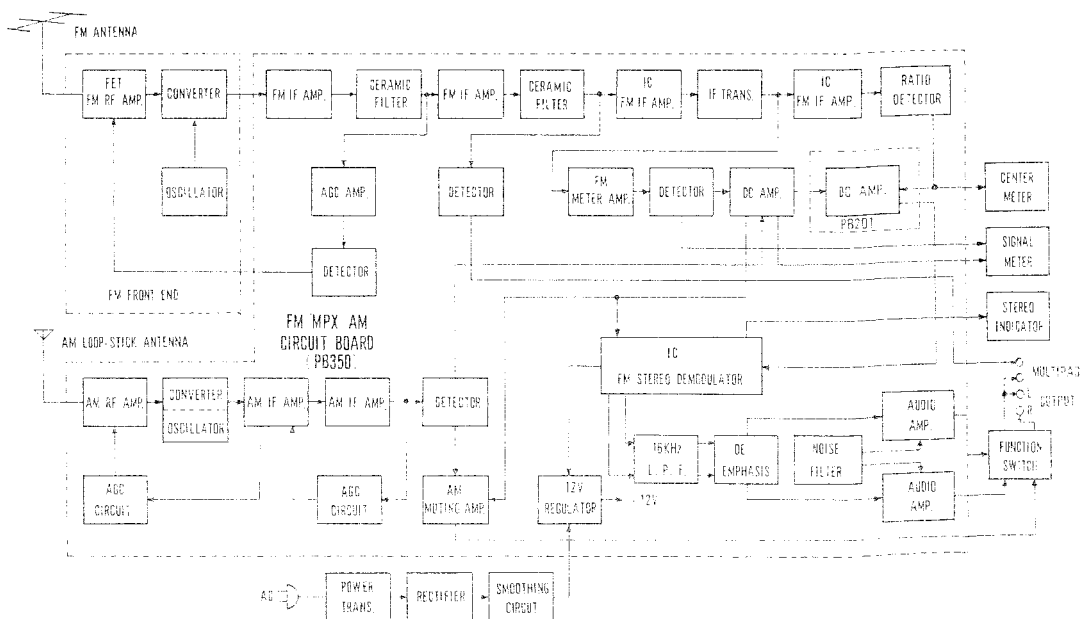

SPECIFICATIONS

FM SECTION

IHF usable sensitivity: 1.8μV (100% mod.)
 Alternate channel selectivity: 70 dB (100 μV, ± 400 KHz)
 AM suppression: 53 dB (1 mV)
 Capture ratio: 1.3 dB
 Image ratio: 90 dB
 IF rejection ratio: 90 dB
 S/N ratio: 70 dB (1 mV, mono)
 Frequency response: 20 – 15,000 Hz (± 1.5 dB)
 Total Harmonic Distortion: 0.3% (400 Hz mono)
 0.4% (400 Hz stereo)
 Separation: 40 dB (400 Hz)
 30 dB (100 – 6 KHz)
 SCA rejection ratio: 60 dB
 Tuning frequency: 88 – 108 MHz
 Output: 1.5V (100% mod.)

AM SECTION

IHF usable sensitivity: 280 μV/m (30% mod., internal antenna)
 Image ratio: 80 dB (external antenna)
 IF rejection ratio: 75 dB (external antenna)
 S/N ratio: 45 dB (10 mV, 30% mod.)
 Frequency response: 80 – 3,000 Hz (-3 dB)
 Total Harmonic Distortion: 1% (400 Hz)
 Tuning frequency: 535 – 1605 KHz
 Output: 550 mV (30% mod.)

COMPOSITION ETC.

Composition: FET(1), IC(3), Transistor(25), Diode(15)
 Annexed devices: muting switch(FM, AM), treble noise filter(FM stereo), output level set ter(FM, AM), multi-path detector(FM)
 Dimensions: 450mm(W) x 268mm(D) x 160mm(H)
 Weight: 7.5 kg

WL 550 ALIGNMENT PROCEDURE

The alignment procedure described in each chart may be performed independently, without affecting the others. Warm up the signal generators for at least 15 minutes to make certain if they are stabilized at their operating temperature particularly generators containing vacuum tubes. Consult the instruction manual supplied with the particular test instrument for specific information concerning connection and operation.

The test equipment listed here is intended only as a guide, but alternate instruments should be of similar quality. The following instruments are required for a complete alignment of the tuner.

1. Measurement instruments and tools

Signal source	1) FM signal generator (FMSG)	Meguro MSG-285A or equivalent
	2) Sweep generator (SWG)	JRC NJM-5217C or equivalent
	3) AM signal generator (AMSG)	Meguro MSG-221C or equivalent
	4) FM stereo modulator (MPXSG)	Sound technology-1000A or equivalent
	5) Audio oscillator (AFO)	Oscillation freq. range 10-100,000Hz, calibration error within 0.2%, distortion 0.1%
Output indicator	6) AM standard loop antenna	Meguro MLA-1001B or equivalent
	7) Oscilloscope (CRO)	Iwatsu SS-5057V or equivalent
	8) Distortion meter (HDM)	Shibaden CR-6S or equivalent
	9) AC volt meter (ACVTVM)	Kikusui 164 or equivalent
Tools	10) DC volt meter (DCVTVM)	Kikusui 107A or equivalent
	11) Hex head alignment tool	
	12) Thin plastic shaft alignment tool	

2. General alignment conditions

- 1) The normal test voltage is 220V R.M.S. 50Hz with less than 2% harmonic distortion.
- 2) Unless otherwise specified, the normal ambient temperature is 15-25°C and humidity 55-75%. But as far as correct judgement is ensured 5-35°C, 45-85% is allowable.
- 3) FM dummy antenna shall be as follows if not otherwise specified. The output voltage of the signal generator is 1/4 of the unloaded terminal voltage.

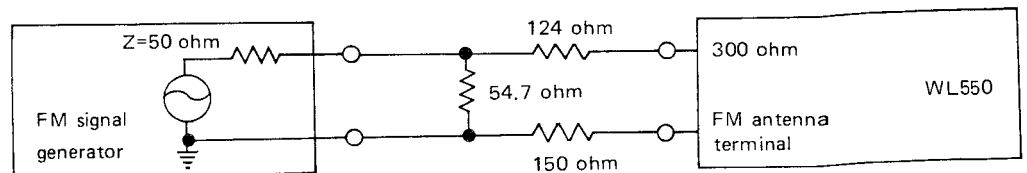

- 4) Connect the low side of signal source and the output indicator to the chassis ground as close as possible to the high side connection unless otherwise specified.
- 5) The 10.7 MHz marker used in each section of the alignment should be the same.
- 6) Marker insertion and amplitude should not distort the oscilloscope trace.
- 7) The AM standard loop antenna should be set above the ferrite loopstick antenna.
- 8) The output level of the sweep generator is measured by the output attenuator regardless of its terminated impedance.
- 9) FM modulation 100% with ± 75 KHz.

Step.	Signal Source Connected to	Set Signal to	Set Radio Dial to	Output Indicator Connected to	Adjust	Adjust for
1	Set selector switch to FM mono, muting switch to off, noise filter switch to off and the mains power switch to off					
2	Press power switch for on					
3				DCVTVM PB350 27 point	VR203	12 ~ 13 DCVTVM reading
4				ref. circuit diagram		Check each part voltage if necessary
5	<u>Sweep generator</u> Point 11 of PB350	± 400KHz sweep centred at 10.7MHz generator output level 90-100	Quiet point on band	<u>Oscilloscope</u> PB350 29		Find a centre frequency where symmetrical response can be obtained in the vicinity of -3dB ~ -6dB and make note of it.
6				<u>Oscilloscope</u> + to PB350 32 and - to 31	T201 T202 core	Symmetrical response centred at the frequency noted by step 5.
7				<u>Oscilloscope</u> through 100KΩ series to wire underneath the right part of PB350, T203	T203 top core	Maximum linearity and amplitude of "S" curve centered at the frequency noted by step 5.
8					T203 bottom core	
9	<u>FM Signal generator</u> Across FM antenna ter- minals (300Ω) through matching network	Reduce the output level to zero. (interstation receiving condition)	Quiet point on band near 98MHz		T203 top core	Centre indication of the tuning meter
10		98MHz at 400Hz 100% modulation output level 1mV	Correct rece- ption of 98 MHz signals from FMSG at the centre of tuning meter	<u>Oscilloscope</u> distortion meter <u>ACVTVM</u> output terminals	T203 bottom core	Maximum reaching of ACVTVM
11					CT201	Minimum distortion
12	Repeat steps 9, 10 and 11 as necessary to obtain maximum output level and minimum distortion at "O" point of tuning meter and to let the meter shows "O" at interstation state					
13	<u>FM signal generator</u> Across FM antenna terminals through 300 ohm matching net work	88MHz at 400Hz 100% modulation, generator output level 1mV	88MHz	<u>Oscilloscope</u> Distortion meter <u>ACVTVM</u>	L104	Accurate reception of 88MHz signals at 88MHz dial calibration
14		108MHz at 400Hz 100% modulation, generator output level 1mV	108MHz	Output terminals	CT104	Accurate reception of 108MHz signals at 108MHz dial calibration

Step.	Signal Source Connected to	Set signal to	Set Radio Dial to	Output Indicator Connected to	Adjust	Adjust for	
15	Repeat steps 13 and 14 as necessary to obtain correct tuning on dial scale.						
16	FM signal generator Across FM antenna terminals through 300Ω matching net work	88MHz at 400Hz 100% modulation generator output level 5-10μV	88MHz		T101 top core	Maximum swing of signal strength meter	
17					T101 bottom core		
18					L101		
19					L102		
20					L103		
21		108MHz at 400Hz 100% modulation generator output level 5-10μV	108MHz		CT101	Centre indication of tuning meter	
22					CT102		
23					CT103		
24		Reduce the output level to zero (interstation receiving condition)	quiet point on band near 98MHz		T203 top core		
25		98MHz at 400Hz 100% distortion generator output level 1mV	correct rece- ption of 98 MHz signals from FMSG at the centre of tuning meter	Oscilloscope distortion meter <u>ACVTVM</u> Output terminals	T203 bottom core		Maximum reading of ACVTVM
26					CT201		Minimum distortion below 0.25% and output level 1.2 – 1.9v
27	Repeat steps 24, 25 and 26 as necessary to obtain the maximum output level and minimum distortion at "O" point of tuning meter and to let the meter show "O" at interstation state.						
28	FM signal generator Across FM antenna terminals through 300Ω matching net work	108MHz at 400Hz 100% modulation	108MHz	Oscilloscope distortion meter <u>ACVTVM</u> Output terminals		IHF maximum usable sensitivity which is the minimum output level of FMSG required for distortion and noise to be -30dB of total output	
29		88MHz at 400Hz 100% modulation	88MHz				
30	Repeat steps 16 ~27 (if necessary 13 ~27) so that the maximum IHF usable sensitivity can be obtained.						
31	FM signal generator Across FM antenna terminals through 300Ω matching net work	98MHz at 400Hz 100% modulation output level 7μV	98MHz		VR203	Swing of signal strength meter within 1 or 1 ±0.5 calibration scale	
32	Put the muting switch to "on".						

Step.	Signal Source Connected to	Set signal to	Set Radio Dial to	Output Indicator Connected to	Adjust	Adjust for
33	FM signal generator Across FM antenna terminals through 300Ω matching net work	98MHz at 400Hz 100% modulation generator output level 7μV	98MHz	Oscilloscope ACVTVM Output terminal	VR201	Fix VR201 at the point where output signals appear
34	Set the function switch to "FM auto stereo" and the muting switch to "off".					
35	FM signal generator Across FM antenna terminals through 300Ω matching net work	98MHz at 19KHz 3-4% modulation generator output level 1mV	98MHz	Oscilloscope TP204	T204 (Black) core	Maximum amplitude of oscilloscope
36					T206 (Black) core	
37					T205 (Yellow) core	
38	Repeat steps 35 ~37 as necessary for alignment of perfect tuning.					
39	FM signal generator Across FM antenna terminals through 300Ω matching net work	98MHz at 19KHz 10% (L-R) 400Hz 45% or 90% output level 1mV	98MHz	Oscilloscope distortion meter ACVTVM Output terminal	T205	To obtain peak of output voltage turning T205 (yellow) core
40	Set the function at AM position.					
41	Connect T202 and T203 on PB350.					
42	Output of sweep generator to PB350 16 and frame of variable capacitor through 1μF mylar capacitor	± 40KHz sweep centred at 455KHz generator output level 80-90dB	Quiet point on band near 1600KHz	Oscilloscope PB350 terminal 24	T209 top core	Maximum symmetrical response centred at 455KHz with same height at 450KHz and 460KHz
43					T209 bottom core	
44					T210 top core	
45					T210 bottom core	
46					T211 core	
47	Remove wiring at step 41.					
48	Connect the terminal 17 of PB350 with the frame of variable capacitor.					

Step.	Signal Source Connected to	Set signal to	Set Radio Dial to	Output Indicator Connected to	Adjust	Adjust for
49			Quiet point on band near 1600KHz	DCVTVM TP201 on PB350	VR202	10V on DCVTVM reading
50	Remove wiring at step 48.					
51	Standard radiating loop antenna placed near AM built-in antenna	600KHz at 400 Hz, 30% modulation field strength 50dB/m	600KHz	Oscilloscope ACVTVM Output terminal	T208 core	dial pointer to be tuned at 600KHz
52					Bar antenna coil L1	Maximum ACVTVM reading - Slide coil bobbin
53					T207 core	Maximum ACVTVM reading
54		1,400KHz at 400Hz, 30% modulation field strength 50dB/m	1400KHz		TC3	dial pointer to be tuned at 1,400KHz
55					TC2	Maximum ACVTVM reading
56					TC1	
57	Repeat steps 51 ~ 56 as necessary to obtain maximum sensitivity and exact tuning point on dial scale.					
58	Fix by adhesive agent the core and bobbin aligned at step 52.					
59	Set the muting switch at "ON".					
60	Standard radiating loop antenna placed near AM built-in antenna	1,000KHz at 400Hz, 30% modulation field strength 56dB/m	1000KHz	Oscilloscope ACVTVM Output terminal	VR202	Fix VR202 at the point where output signals appear
61	Set the muting switch at "OFF".					
62	Standard radiating loop antenna placed near AM built-in antenna	600KHz at 400Hz, 30% modulation	600KHz	Oscilloscope ACVTVM Distortion Meter Output terminal		IHF maximum usable sensitivity which is equivalent electric field strength at the loopstick antenna adjusted by attenuator of AMMSG so that noise and distortion can be -20dB of total output.
63		1,400KHz at 400Hz 30% modulation	1400KHz			
64	Put the power switch to "off". Remove all connections among the tuner, measuring instruments and main power sources.					

SEMICONDUCTOR SPECIFIC CHART

TRANSISTORS (Ta = 25°C)

Type	MAX. RATING			CHARACTERISTICS								
	Pt	Vceo	Ic	hfe				fT MHz				NF
	W	V	mA	min	max	Ic mA	Vce V	min	tye	Ic mA	Vce	maxdB
2SC381	0.1	30	20	40	140	1	6	250	---	1	6	---
2SC372	0.2	30	100	70	240	10	1	80	200	1	10	---
2SC1000	0.2	50	100	200	1200	2	6	---	80	2	6	2
2SC735	0.3	30	400	70	240	100	1	---	300	50	5	---
2SD235	1.5	35	3000	40	240	500	5	---	1	500	5	---
2SC535	0.1	20	20	35	200	1	6	450	700	5	6	5.5
SE3001	0.2	12	---	---	---	---	---	---	---	---	---	4

FIELD EFFECT TRANSISTORS (Ta = 25°C)

Type	MAX. RATING			CHARACTERISTICS							
	Pch	V _{G1SS} , V _{G2SS}	I _{G1} , I _{G2}	I _{DSS} mA			Cr _{ss}	NF			
	mW	V	mA	min	max	V _{ds} V	pF	tye	V _{ds} V		
3SK30	200	-15	10	3	20	10	0.6	10	2.0	10	

DIODES (Ta = 25°C)

Type	MAX. RATING			CHARACTERISTICS			
	IF	Vr	Surge	If		Ir	
	A	V	A	mA	Vf V	μA	Vr V
1S188	0.05	-35	0.5	0.004	0.1	-75	-10
KB165	0.05	---	---	0.003	0.65	---	---
KB265	0.03	---	---	0.003	1.31	---	---
SIRC10	1.8	-100	30	0.9A	1.05	-10	-100

INTEGRATED CIRCUIT SPECIFIC CHART

μPC554C

ABSOLUTE MAXIMUM RATING (Ta = 25°C)

	Symbol	Rating	Unit
Supply voltage	V _{cc}	15	V
Max. device current	I _{cc}	18	mA
Lamp driver current, max.	I _L	100	mA
Device dissipation, max.	P _D	400	mW
Operating temperature	T _{opr}	0 ~ ± 75	°C
Storage temperature	T _{stg}	40 ~ ± 125	°C

ELECTRICAL CHARACTERISTICS (Ta = 25°C, Vcc = +9.0V)

	Symbol	Circuit for measurement	Condition of measurement	Min.	Typ.	Max.	Unit
Circuit current	I _{cc}	1	at zero signal		10	18	mA
Input impedance	Z _i	1			20		KΩ
Separation			f = 100Hz		35		dB
			f = 1KHz		45		
			f = 10KHz		30		
Gain (dB)	A _v	1	38KHz B.E.F		-1.5		dB
Channel balance	ch. B	1	(Mono)		0.2	2.0	dB
Distortion	T.H.D		(Mono)		0.5	1.0	%
Audio / muting changeover level	Mute OFF	1			0.85	1.00	V
	Mute ON	1		1.00	1.08		
Sensitivity of stereo indicator lamp	Lamp ON	1	(Pilot level)		12		mV
	Lamp OFF	1			8.4		
Stereo / mono changeover level	STEREO	1		1.00	1.13		V
	MONO	1			0.82	1.00	
AM suppression	19KHz		(within 1KHz)		30		dB
	38KHz					25	
SCA rejection	SCA Rejection				55		dB
Muting		1		45	55		dB

- Note 1. Condition of measurement = input signal 200mVrms (Pilot 10%), frequency 1KHz.
 2. R.P.F of f = 15KHz shall be used for separation measurement.

EQUIVALENT CIRCUIT

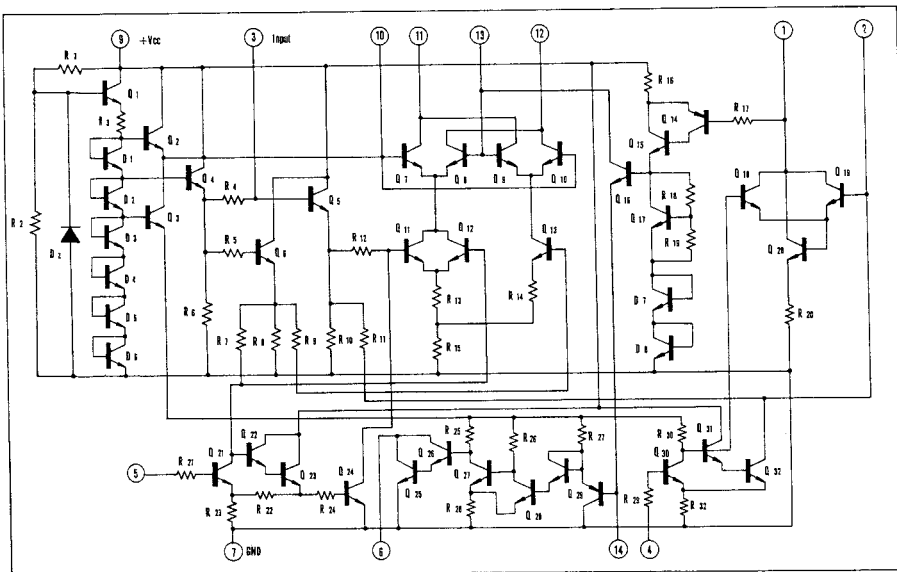

PIN CONNECTOR (Top view)

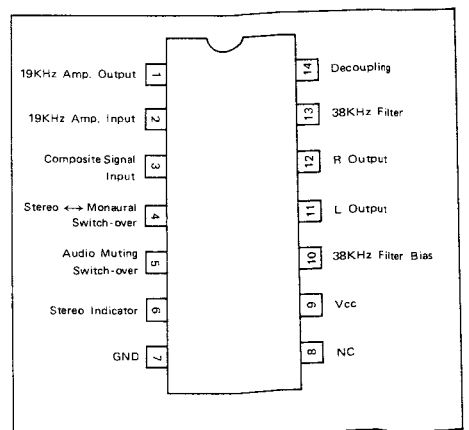

INTEGRATED CIRCUIT SPECIFIC CHART

TA 706P

MAXIMUM LIMITS OF DEVICE (Ta = 25°C)

	Symbol	Rating	Unit
Max. Vcc	Vcc	8.5	V
Input voltage (terminals 6 - 7)	VI	±3	V
Max. dissipation	PD	300	mW
Operating temperature (Vcc = 7.5V)	Topr	-30~75	°C
Storage temperature	Tstg	-55~125	°C

ELECTRICAL SPECIFICATION (Ta = 25°C)

	Symbol	Condition of measurement	Min.	Typ.	Max.	Unit
Current vs supply Vcc	Icc	Vcc = 6.0V	8	13	18	mA
		Vcc = 7.5V	10	15	20	
Gain (dB)	Gp	Vcc = 7.5V, f = 10.7MHz	65	68	71	dB
Input impedance	RI	Vcc = 7.5V, f = 10.7 MHz	-	2.7	-	KΩ
Input capacitance	CI		-	7.1	-	pF
Output impedance	Ro	Vcc = 7.5V, f = 10.7MHz	-	90	-	KΩ
Output capacitance	Co		-	4.6	-	pF
Input voltage for full limiting	VI(lim)	Vcc = 7.5V, RL = 1KΩ	-	600	-	μV

EQUIVALENT CIRCUIT

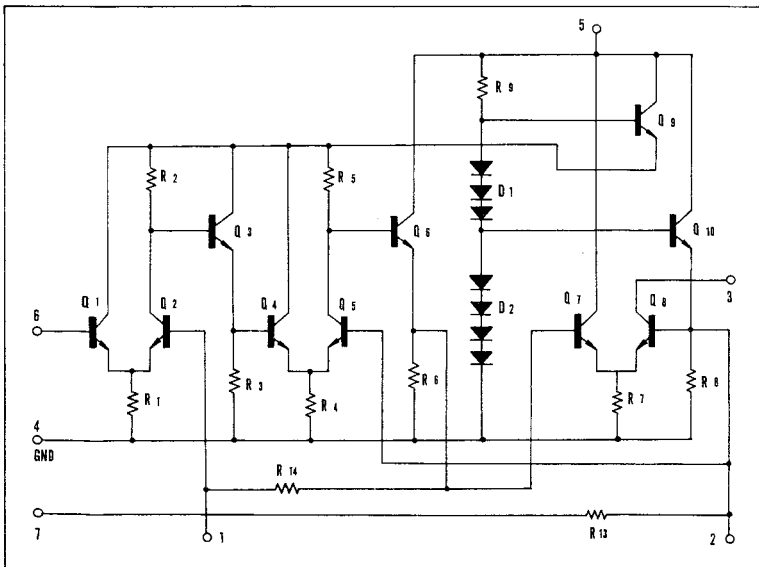

PIN CONNECTION

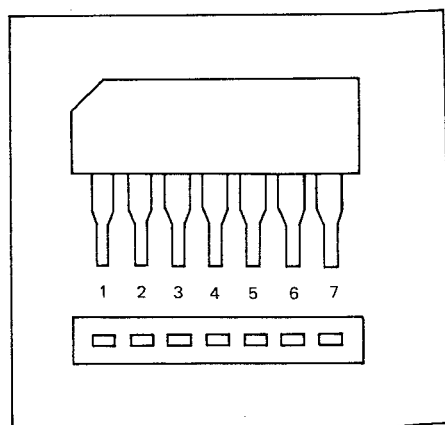

SCHEMATIC FOR 117V OPERATION

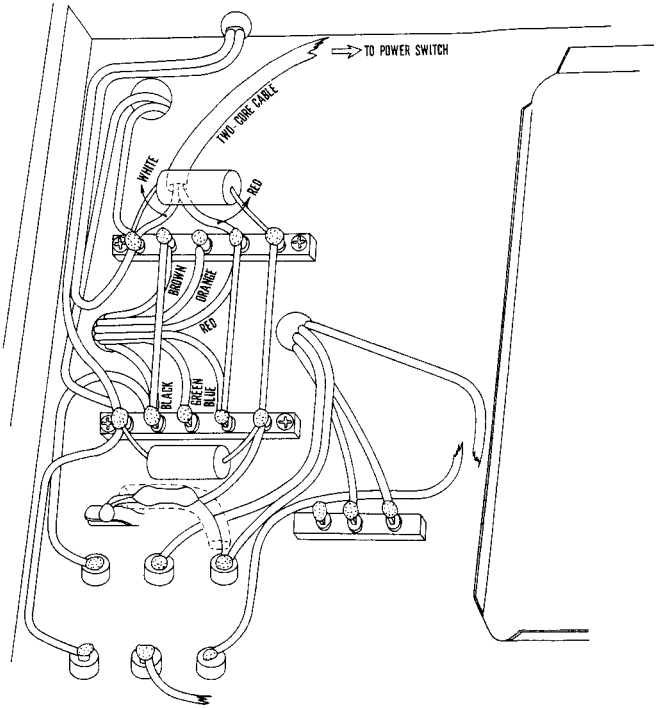

SCHEMATIC FOR 220V OPERATION

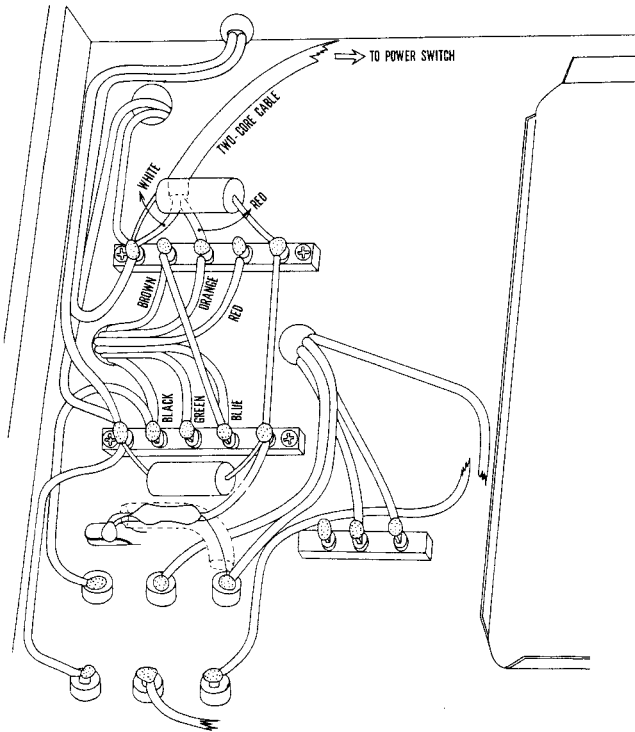

SCHEMATIC FOR 240V OPERATION

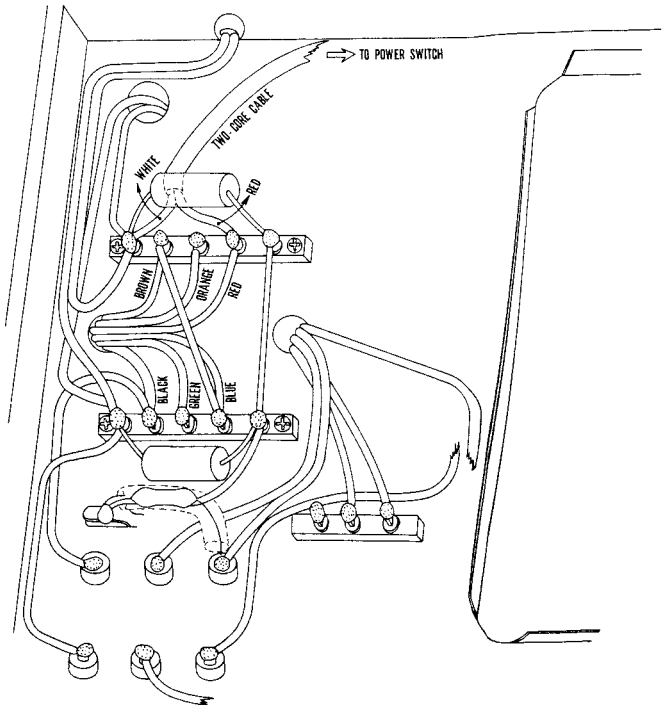

PB350 CIRCUIT BOARD COMPONENT LOCATION COMPONENT VIEW

R201 X1	R261 Z3	C201 X1	C268 Z4	F201 X1
R202 X1	R262 Z3	C202 X1	C269	F202 X1
R203 X1	R263 Z3	C203	C270 Y2	F203 Y3
R204 PB350 BOTTOM	R264 Z3	C204 X1	C271 Z2	T201 X2
R205 X1	R265 Z3	C205 X2	C272 Y2	T202 X2
R206 X1	R266 Z2	C206 X2	C273 Y1	T203 X3
R207 X1	R267 Z3	C207 X2	C274 Y1	T204 Y4
R208 X1	R268 Z3	C208 X2	C275 Y1	T205 Y4
R209 X1	R269 Z3	C209 X3	C276 Z2	T206 Y4
R210	R270 Z3	C210 X3	C277 Y2	T207 Z1
R211 X2	R271 Z4	C211 X3	C278 Y1	T208 Z1
R212 X2	R272 Z4	C212 X3	C279 Y1	T209 Z2
R213 X2	R273 Z4	C213 X4	C280 Y1	T210 Z2
R214 X3	R274 Z4	C214 X3	C281 X4	T211 Z3
R215 X3	R275 Z4	C215	C282 X4	⑪ X1
R216 PB350 BOTTOM	R276 Z4	C216 X4	C283 Z1	⑫ X1
R217 X3	R277 Y2	C217 X4	C284 Z2	⑬ Y1
R218 X4	R278 Y2	C218 X1	C285 X1	⑭ Z1
R219 X4	R279	C219 X1	C286 Y2	⑮ Z1
R220 X4	R280 Y2	C220 X1	C287 X4	⑯ Z1
R221	R281 Y3	C221 Y1	C288 X4	⑰ Z1
R222 X4	R282 Y3	C222 X1	C289 X4	⑱ X4
R223 X4	R283 Y3	C223 X1	C290 Z4	⑲ Y4
R224	R284 X3	C224 X2	VR201 Y2	⑳ Y2
R225 X1	R285 Z4	C225 X2	VR202 Z3	㉑ X1
R226 X1	R286 Z4	C226 X2	VR203 X1	㉒ Z4
R227 X1	R287 Z4	C227 X2	CT201 X3	㉓ Z4
R228 Y1	R288 Z4	C228 Y2	D201 Y1	㉔ Z4
R229 X1	R289 Y1	C229 Y2	D202 Y2	㉕ Z3
R230	R290 Y3	C230 X4	D203 X2	㉖ Z4
R231 X1	R291 X4	C231 X4	D204 Y2	㉗ X1
R232 Y3	R292 Y2	C232 Y3	D205 X2	㉘ X2
R233 X3	R293 Y3	C233 Y3	D206 X4	㉙ X3
R234 X2	R294 Y3	C234 Y4	D207 X4	㉚ X2
R235 X2	R295 Y2	C235 Y3	D208 X3	㉛ Y2
R236 Y2	R296 Y2	C236 Y4	D209 Z3	㉜ Y3
R237 Y2	R297 Y2	C237 Z1	D210 Z3	㉝ Y3
R238 X2	R298 Y1	C238 Z1	D211 Z3	㉞ X4
R239 X4	R299 Y1	C239 Z1	D212 Z4	㉟ X4
R240 Y3	R300 Y1	C240 Z2	D213 Z2	㊱ Y2
R241 Y3	R301 Z1	C241 Z1	Q201 X1	㊲ Z1
R242 Y4	R302 Y1	C242	Q202 X1	㊳ Y2
R243 Y3	R303 Y1	C243 Z1	Q203 X2	㊴ Z2
R244 Y3	R304 X3	C244 Z1	Q204 X3	㊵ X3
R245 Z1	R305 Y2	C245 Z1	Q205 X1	㊶ X3
R246 Z1	R306 Y2	C246 Z1	Q206 X2	㊷ X4
R247 Z1	R307 Y1	C247 Z1	Q207 Y4	TP201 Z1
R248 Z1	R308 Y1	C248 Z2	Q208 Z1	TP202 Z3
R249 Z1	R309 Y1	C249 Z2	Q209 Z1	TP203 Z3
R250 Z1	R310 Y1	C250 Z2	Q210 Z2	TP204 Z4
R251 Z1	R311 Y1	C251	Q211 Z3	
R252	R312 Y1	C252 Z3	Q212 Z4	
R253 Z2	R313 Y1	C253 Z3	Q213 Y2	
R254 Z2	R314 Z1	C254 Z3	Q214 Y2	
R255 Z2	R315	C255 Z3	Q215 Y2	
R256 Z2	R316	C256 Z3	Q216 Y3	
R257 Z2	R317	C257 Z3	Q217 Z4	
R258 Z2	R318 X4	C258 Z4	Q218 Z4	
R259 Z2	R319	C259 Z3	Q219 Z4	
R260 Z2	R320 X4	C260 Z4	Q220 Y2	
	R321 Z4	C261 Z4	Q221 Y1	
	R322 X4	C262 Z4	Q222 Y1	
		C263 Y2	Q223 Y1	
		C264 Y2		
		C265 Y2		
		C266 Y3		
		C267 Z4		

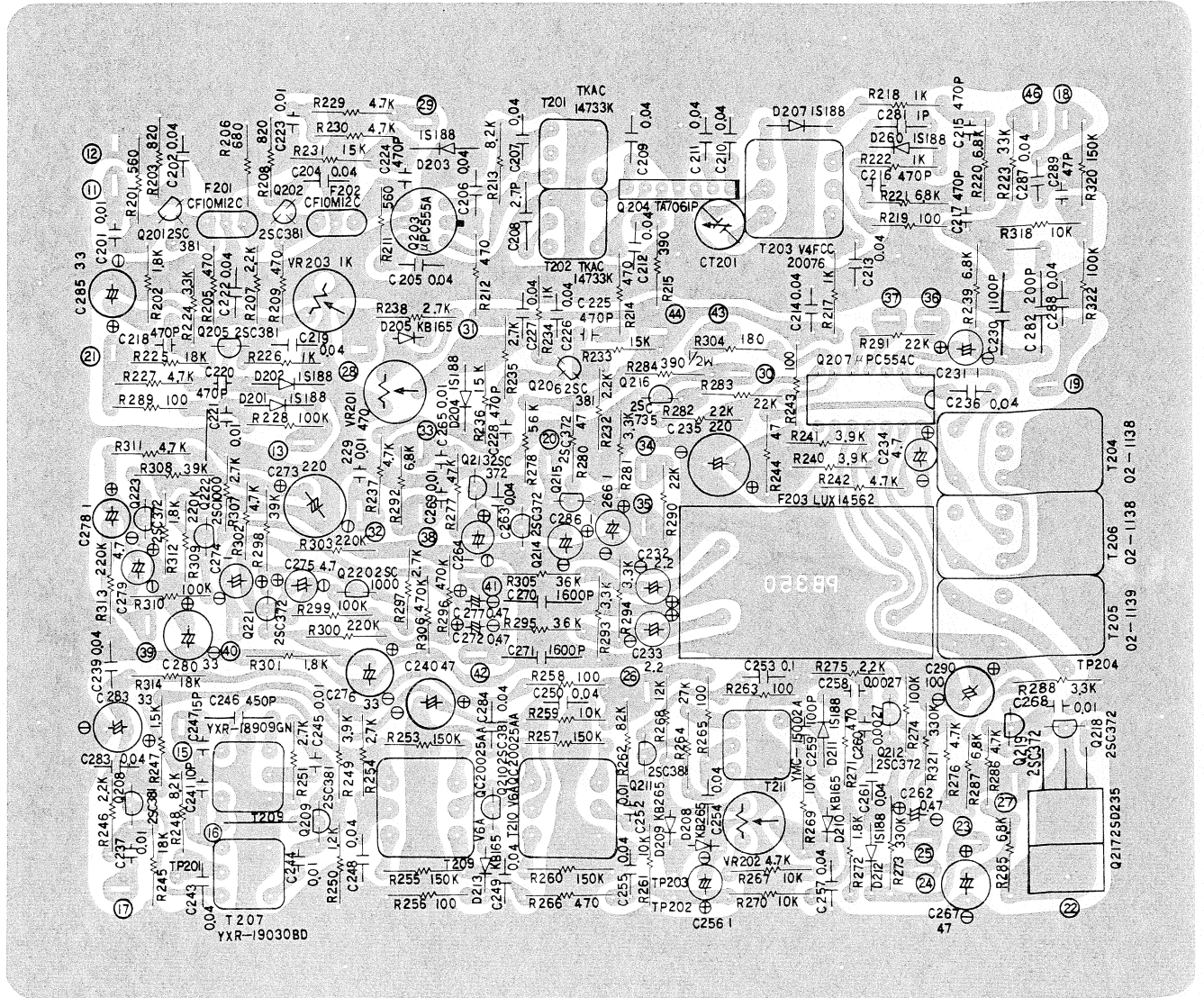

PB201

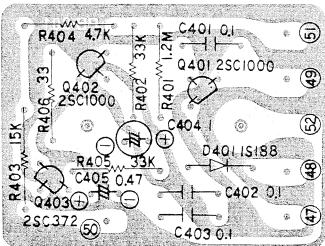

DISASSEMBLY

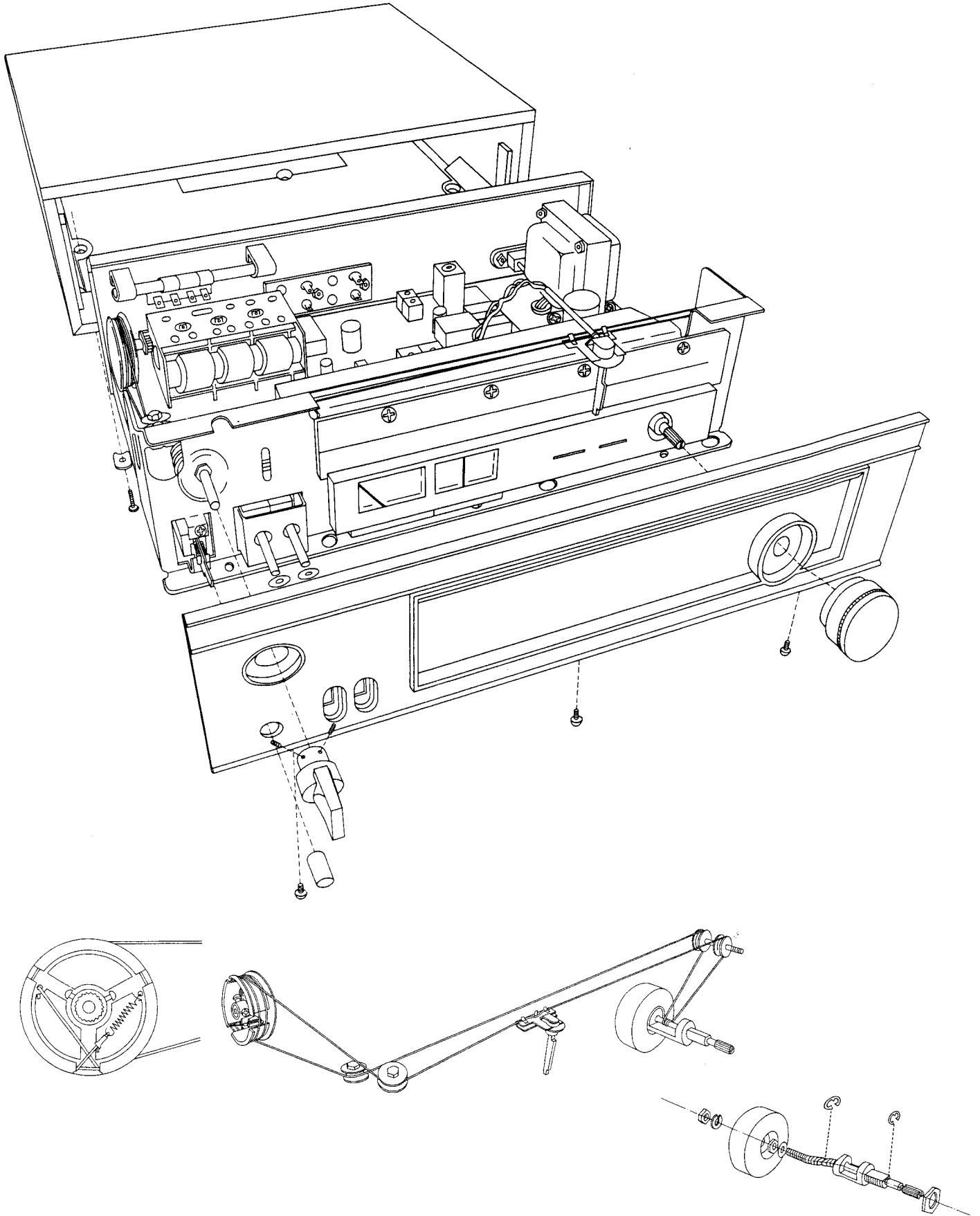

REPLACEMENT PARTS

RESISTORS: $\pm 10\%$ $\frac{1}{4}$ watt deposited carbon, unless noted otherwise

SYMBOL NO.	DESCRIPTION	SYMBOL NO.	DESCRIPTION	SYMBOL NO.	DESCRIPTION	SYMBOL NO.	DESCRIPTION
R1	470 Ω	R229	4.7K	R263	100 Ω	R297	2.7K
R2	470 Ω	R230	4.7K	R264	27K	R298	39K
R3	100 Ω	R231	15K	R265	100 Ω	R299	100K
R4	1 Ω	R232	2.2K	R266	470 Ω	R300	220K
R5	33K	R233	15K	R267	10K	R301	1.8K
R6	150K	R234	1K	R268	12K	R302	4.7K
R201	560 Ω	R235	2.7K	R269	10K	R303	220K
R202	1.8K	R236	15K	R270	10K	R304	180 Ω
R203	820 Ω	R237	4.7K	R271	470 Ω	R305	36K
R204	1.5K	R238	2.7K	R272	1.8K	R306	470K
R205	470 Ω	R239	6.8K	R273	330K	R307	2.7K
R206	680 Ω	R240	3.9K	R274	100K	R308	39K
R207	2.2K	R241	3.9K	R275	2.2K	R309	220K
R208	820 Ω	R242	4.7K	R276	4.7K	R310	100K
R209	470 Ω	R243	100 Ω	R277	47K	R311	4.7K
R210		R244	47 Ω	R278	56K	R312	1.8K
R211	560 Ω	R245	18K	R279		R313	220K
R212	470 Ω	R246	2.2K	R280	47 Ω	R314	18K
R213	8.2K	R247	1.5K	R281	3.3K	R315	
R214	1K	R248	8.2K	R282	22K	R316	
R215	390 Ω	R249	3.9K	R283	22K	R317	
R216	8.2K	R250	1.2K	R284	$\frac{1}{2}$ W 390 Ω	R318	10K
R217	1K	R251	2.7K	R285	6.8K	R319	
R218	1K	R252		R286	4.7K	R320	150K
R219	100 Ω	R253	150K	R287	6.8K	R321	330K
R220	6.8K	R254	2.7K	R288	3.3K	R322	100K
R221	6.8K	R255	150K	R289	100 Ω		
R222	1K	R256	100 Ω	R290	22K	R401	1.2M
R223	33K	R257	150K	R291	22K	R402	33K
R224	3.3K	R258	100 Ω	R292	6.8K	R403	15K
R225	18K	R259	10K	R293	3.3K	R404	4.7K
R226	1K	R260	150K	R294	3.3K	R405	33K
R227	4.7K	R261	10K	R295	36K	R406	33 Ω
R228	100K	R262	82K	R296	470K		

CAPACITORS

SYMBOL NO.	DESCRIPTION	SYMBOL NO.	DESCRIPTION
C1	10pF ± 1 pF NPO., 50WV ceramic	C212	0.04 μ F +80% -20% 50V ceramic
C2	0.01 μ F +80% -20% 50WV ceramic	C213	0.04 μ F +80% -20% 50V ceramic
C3	0.01 μ F +80% -20% 50WV ceramic	C214	0.04 μ F +80% -20% 50V ceramic
C4	4700pF $\pm 20\%$ 250V r.m.s polyester film	C215	470pF $\pm 20\%$ 50V ceramic
C5	4700pF $\pm 20\%$ 250V r.m.s polyester film	C216	470pF $\pm 20\%$ 50V ceramic
C6	2200 μ F +100% -10% 25V electrolytic	C217	470pF $\pm 20\%$ 50V ceramic
C7	47 μ F +50% -10% 16V electrolytic	C218	470pF $\pm 20\%$ 50V ceramic
C8	450pF $\pm 5\%$ 50WV polystyrol	C219	0.04 μ F +80% -20% 50V ceramic
C9	2200pF $\pm 20\%$ AC200V polyester	C220	470pF $\pm 20\%$ 50V ceramic
C10	2200pF $\pm 20\%$ AC200V polyester	C221	0.01 μ F +80% -20% 50V ceramic
		C222	0.04 μ F +80% -20% 50V ceramic
C201	0.01 μ F +80% -20% 50V ceramic	C223	0.01 μ F +80% -20% 50V ceramic
C202	0.04 μ F +80% -20% 50V ceramic	C224	470pF $\pm 20\%$ 50V ceramic
C203		C225	470pF $\pm 20\%$ 50V ceramic
C204	0.04 μ F +80% -20% 50V ceramic	C226	0.04 μ F +80% -20% 50V ceramic
C205	0.04 μ F +80% -20% 50V ceramic	C227	0.04 μ F +80% -20% 50V ceramic
C206	0.04 μ F +80% -20% 50V ceramic	C228	470pF $\pm 20\%$ 50V ceramic
C207	0.04 μ F +80% -20% 50V ceramic	C229	0.01 μ F +80% -20% 50V ceramic
C208	2.7pF $\pm 5\%$ 500V small molded	C230	1100pF $\pm 5\%$ 50V polystyrol
C209	0.04 μ F +80% -20% 50V ceramic	C231	1 μ F +75% -10% 25V electrolytic
C210	0.04 μ F +80% -20% 50V ceramic	C232	2.2 μ F +75% -10% 25V electrolytic
C211	0.04 μ F +80% -20% 50V ceramic	C233	2.2 μ F +75% -10% 25V electrolytic

SYMBOL NO.	DESCRIPTION
C234	4.7 μ F +50% -10% 25V electrolytic
C235	220 μ F +50% -10% 16V electrolytic
C236	0.04 μ F +80% -20% 50V ceramic
C237	0.01 μ F +80% -20% 50V ceramic
C238	0.04 μ F +80% -20% 50V ceramic
C239	0.04 μ F +80% -20% 50V ceramic
C240	47 μ F +50% -10% 16V electrolytic
C241	10pF \pm 1pF NPO 50V ceramic
C242	
C243	0.04 μ F +80% -20% 50V ceramic
C244	0.01 μ F +80% -20% 50V ceramic
C245	0.01 μ F +80% -20% 50V ceramic
C246	450pF \pm 5% 50WV polystyrol
C247	15pF \pm 10% 50V ceramic
C248	0.04 μ F +80% -20% 50V ceramic
C249	0.04 μ F +80% -20% 50V ceramic
C250	0.04 μ F +80% -20% 50V ceramic
C251	
C252	0.04 μ F +80% -20% 50V ceramic
C253	0.1 μ F +80% -20% 25V ceramic
C254	0.04 μ F +80% -20% 50V ceramic
C255	0.04 μ F +80% -20% 50V ceramic
C256	1 μ F +75% -10% 25V electrolytic
C257	0.04 μ F +80% -20% 50V ceramic
C258	2700pF \pm 10% 50V mylar
C259	100pF \pm 10% 50V ceramic
C260	2700pF \pm 10% 50V mylar
C261	0.04 μ F +80% -20% 50V ceramic
C262	0.47 μ F +50% -20% 35V solid tantalum
C263	0.04 μ F +80% -20% 50V ceramic
C264	1 μ F +75% -10% 25V electrolytic
C265	0.01 μ F +80% -20% 50V ceramic

SYMBOL NO.	DESCRIPTION
C266	1 μ F +75% -10% electrolytic
C267	47 μ F +50% -10% 16V electrolytic
C268	0.01 μ F +80% -20% 50V ceramic
C269	0.01 μ F +80% -20% 50V ceramic
C270	1600pF \pm 5% 50V polystyrol
C271	1600pF \pm 5% 50V polystyrol
C272	0.47 μ F +5% -20% 35V solid tantalum
C273	220 μ F +50% -10% 16V electrolytic
C274	1 μ F +75% -10% 25V electrolytic
C275	4.7 μ F +50% -10% 25V electrolytic
C276	33 μ F +50% -10% 16V electrolytic
C277	0.47 μ F +50% -20% 35V solid tantalum
C278	1 μ F +75% -10% 25V electrolytic
C279	4.7 μ F +50% -10% 25V electrolytic
C280	33 μ F +50% -10% 16V electrolytic
C281	1pF \pm 5% 500WV small molded
C282	200pF \pm 5% 50V polystyrol
C283	47 μ F +50% -10% 16V electrolytic
C284	0.04 μ F +80% -20% 50V ceramic
C285	33 μ F +50% -10% 16V electrolytic
C286	1 μ F +75% -10% 25V electrolytic
C287	0.04 μ F +80% -20% 50V ceramic
C288	0.04 μ F +80% -20% 50V ceramic
C289	47p \pm 10% 50V ceramic
C290	100 μ F +50% -10% 6.3V electrolytic
CT201	Trimmer 10pF MAX
C401	0.1 μ F +80% -20% 25V ceramic
C402	0.1 μ F +80% -20% 25V ceramic
C403	0.1 μ F +80% -20% 25V ceramic
C404	1 μ F +75% -10% 25V electrolytic
C405	0.47 μ F +50% -20% 35V solid tantalum

TRANSISTORS

SYMBOL NO.	DESCRIPTION
Q101	FM RF AMP 3SK30
Q102	FM MIXER 2SC535
Q103	FM LOACAL oscilator SE3001
Q201	FM IF AMP 2SC381
Q202	" "
Q203	" μ PC555A (NEC)
Q204	" TA7061P (TOSHIBA)
Q205	FM AGC AMP 2SC381
Q206	SIGNAL METER AMP 2SC381
Q207	MPX and Mute switching μ PC554C (NEC)
Q208	AM RF AMP 2SC381
Q209	AM MIXER 2SC381
Q210	AM IF and AGC AMP 2SC381
Q211	AM IF AMP 2SC381
Q212	AM AUDIO AMP 2SC372
Q213	DC AMP FOR MUTING 2SC372
Q214	" 2SC372
Q215	" 2SC372
Q216	STEREO ONLY circuit 2SC735
Q217	Voltage stabilizer 2SD235
Q218	" 2SC372
Q219	" 2SC372
Q220	FM AUDIO AMP 2SC1000
Q221	" 2SC372
Q222	" 2SC1000
Q223	" 2SC372

SYMBOL NO.	DESCRIPTION
Q401	FM CENTER TUNING prove 2SC1000
Q402	DC AMP FOR MUTING 2SC1000
Q403	" 2SC372

TRANSFORMERS & FILTER

SYMBOL NO.	DESCRIPTION
T201	FM IF TRANS TKAC-14733K
T202	" "
T203	FM DISCRIMINATOR TRANS V4FCC-20076BJK
T204	19KHz TRANS 02-1138
T205	38KHz TRANS 02-1139
T206	19KHz TRANS 02-1138
T207	AM RF TRANS YXR-19030BD
T208	AM LOACAL oscilator trans YXR-18909GN
T209	AM IF TRANS V6AQC20025AA
T210	" "
T211	AM DETECTOR TRANS YMC-15002A
T1	POWER TRANS P-1735V
F203	FM LOW-PASS FILTER TRANS LUX-14562

CIRCUIT DIAGRAM

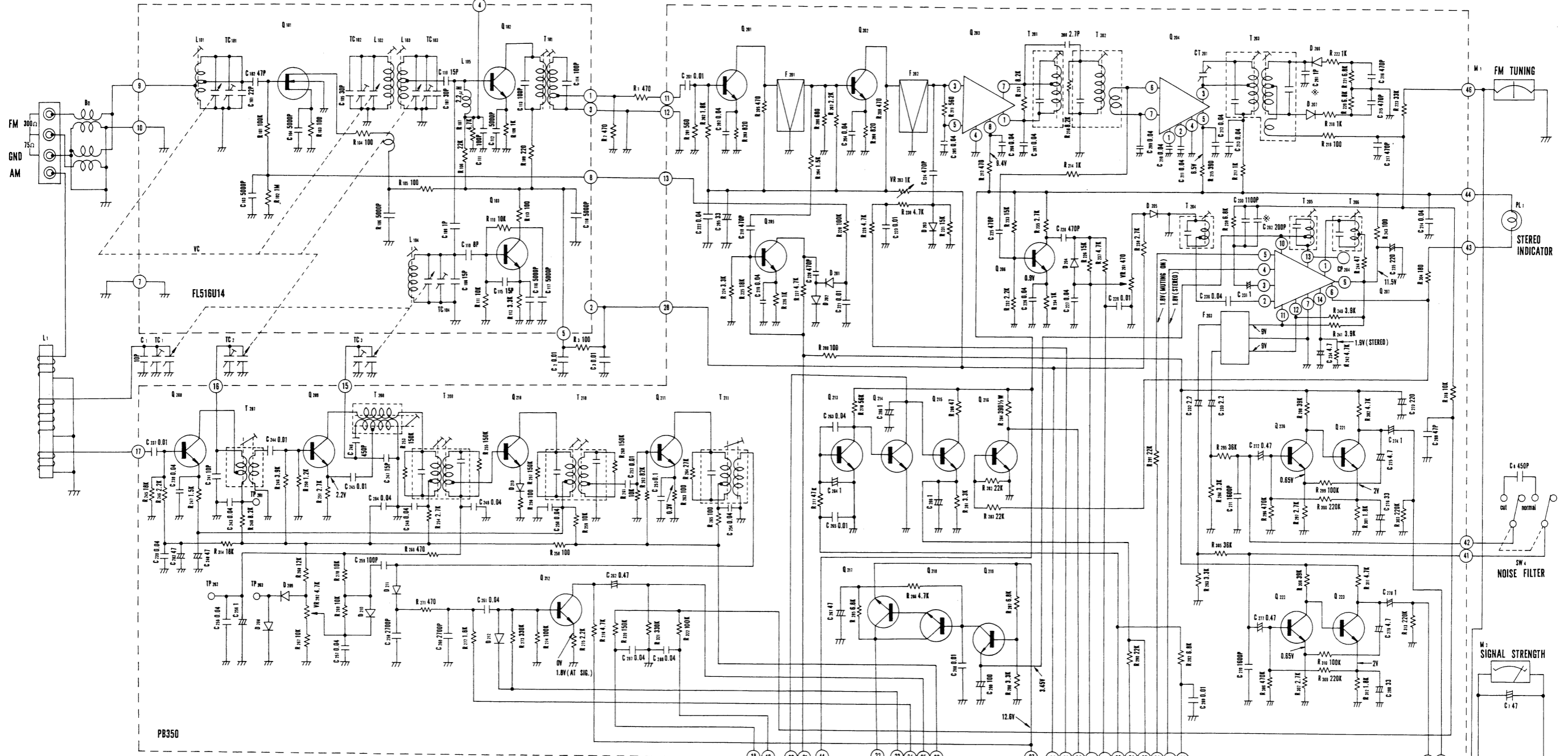

TRANSISTORS & ICs

Q 101	3SK30
Q 102	2SC535
Q 103	SE3001
Q 201, Q 202, Q 205, Q 206	2SC381
Q 208, Q 209, Q 210, Q 211	2SC381
Q 203	PC555A
Q 204	TA7061P
Q 207	PC554C
Q 212, Q 213, Q 214, Q 215, Q 403	2SC372
Q 216, Q 218, Q 221, Q 223	2SD235
Q 217	2SD235
Q 220, Q 222, Q 401, Q 402	2SC1000
Q 216	2SC735

DIODES

D 201, D 202, D 203, D 204, D 401	1S188
D 206, D 207, D 211, D 212	1S188
D 216, D 213, D 205	KB165
D 208, D 209	KB26 5
D 1	S1RC10

LAMPS

PL1	6V180mW
PL2, PL3, PL4, PL5	12V3W
PL6	12V780mW

NOTES

1. ALL RESISTOR IN OHMS ($K = \times 10^3$ $M = \times 10^6$) $\pm 10\%$
2. ALL CAPACITOR IN MICRO FARADS ($P = 10^{-12}$)
3. TRANSISTORS AND DIODES MAY BE REPLACED WITH ANY TYPES HAVING COMPARABLE RATINGS.
4. VOLTAGES MEASURED WITH "VTVM" WITH NO SIGNAL INPUT UNLESS NOTED OTHERWISE
5. THERE MIGHT BE SLIGHT CHANGES IN THE ACTUAL SET. (ESPECIALLY*)

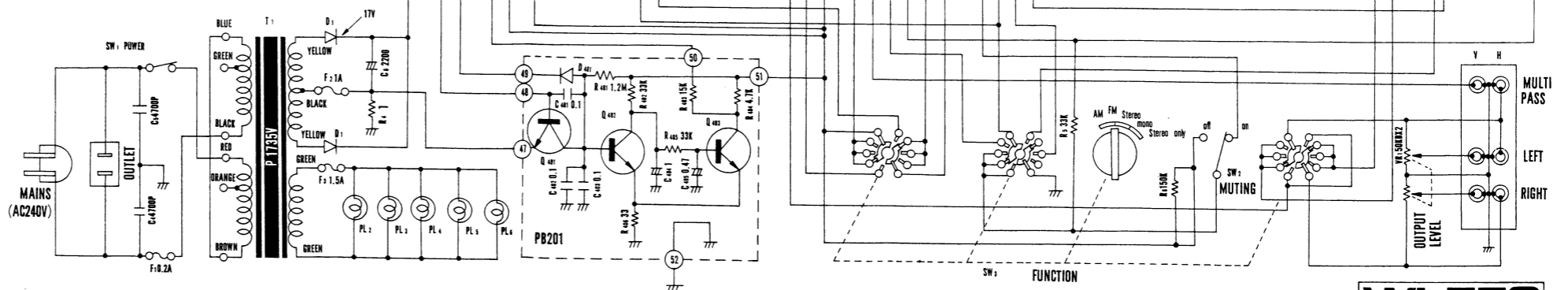

WL550

OUTPUT LEVEL, AM SUPPRESSION, DISTORTION & NOISE

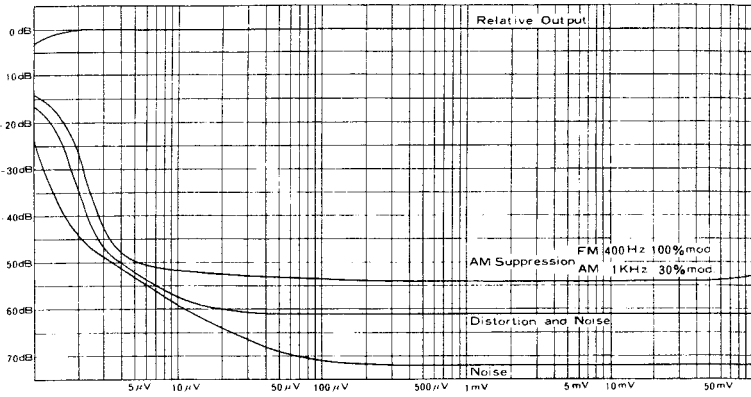

AM SENSITIVITY & IMAGE

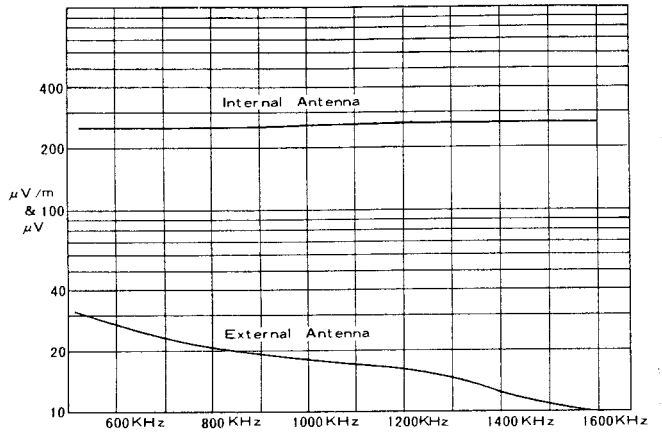

SELECTIVITY

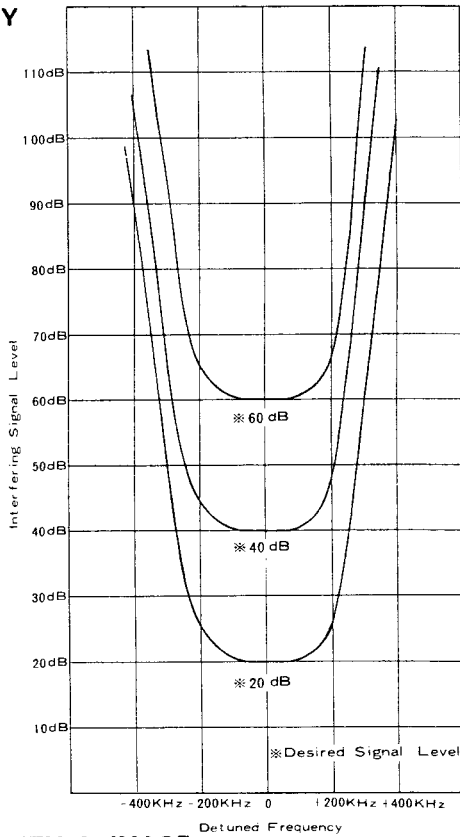

T.H.D. (Input Signal 84MHz/1mV)

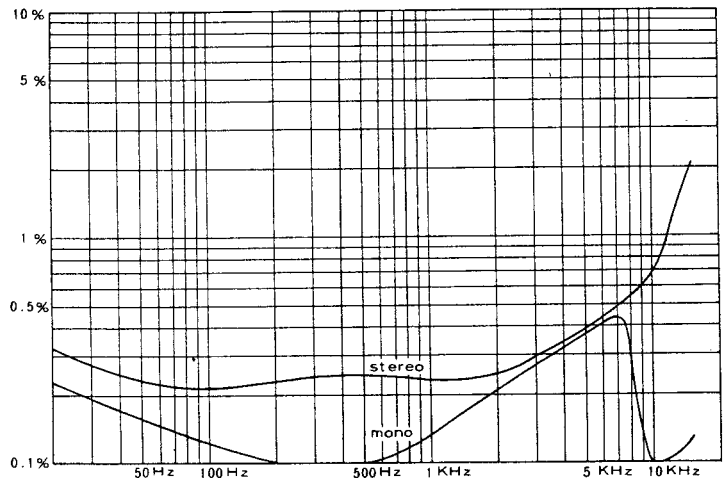

FM SENSITIVITY & IMAGE

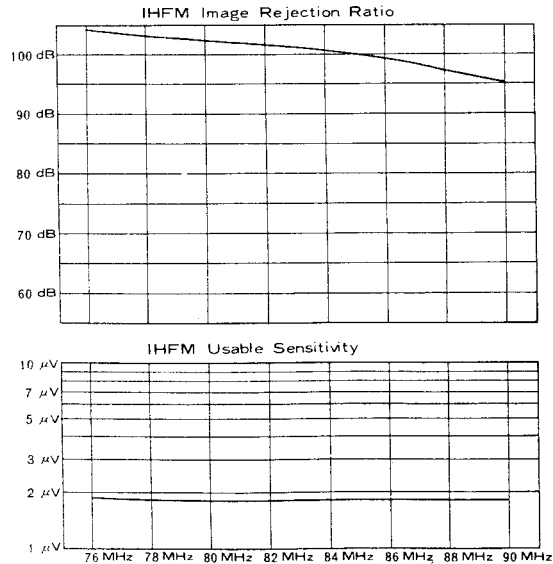

STEREO SEPARATION (Input Signal 83MHz/1mV, Modulation 100%)

