

Service Manual

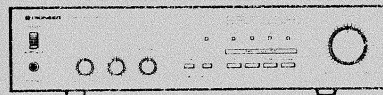

STEREO AMPLIFIER A-110

MODEL A-110 COMES IN THREE VERSIONS DISTINGUISHED AS FOLLOWS:

Type	Power requirement	Export destination
HE	AC220V, 240V (switchable)	European continent
HB	AC220V, 240V (switchable)	United Kingdom
HEZ	AC220V, 240V (switchable)	West Germany

- This service manual is applicable to the HE, HB and HEZ types.
- As to the HB and HEZ types, please refer to pages 12–16.

CONTENTS

1. EXPLODED VIEWS AND PARTS LIST	2	6. FOR HB AND HEZ TYPES	12
2. P.C. BOARDS CONNECTION DIAGRAM	5	7. P.C. BOARDS PATTERN (For HEZ type)	13
3. SCHEMATIC DIAGRAM	7	8. SCHEMATIC DIAGRAM (For HEZ type)	15
4. ELECTRICAL PARTS LIST	9	9. SPECIFICATIONS	18
5. PACKING	11	10. FRONT PANEL FACILITIES	19

1. EXPLODED VIEWS AND PARTS LIST

NOTES:

- Parts without part number cannot be supplied.
- The \triangle mark found on some component parts indicates the importance of the safety factor of the part. Therefore, when replacing, be sure to use parts of identical designation.
- For your parts Stock Control, the fast moving items are indicated with the marks $\star\star$ and \star .
 $\star\star$ **GENERALLY MOVES FASTER THAN \star**
 This classification shall be adjusted by each distributor because it depends on model number, temperature, humidity, etc.
- Parts marked by "◎" are not always kept in stock. Their delivery time may be longer than usual or they may be unavailable.

Parts List

Mark	No.	Part No.	Description	Mark	No.	Part No.	Description
	1	AZN1371	Front panel		26	CKDYF473Z50	Capacitor (C728)
	2	AZN1373	Volume knob	$\star\star$	27	AZE1032	Fuse (FU1, T800mA/250V)
	3	AZN1380	Rotary knob			(AEK-031)	
	4	AZN1068	Badge			(AEK-507)	
		(AAM-030)		\triangle $\star\star$	28	AZE1030	Fuse (FU2, FU3, 2A/250V)
	5	AZN1376	Power escutcheon			(AEK-035)	
	6	AZN1372	Knob escutcheon		29	
	7	AZN1377	Power knob		30	AZE1020	Cord fixer
	8	AZN1378	Push knob "A"		31	
	9	AZN1379	Push knob				
	10	AZN1369	Foot		32	AZB1119	Screw
						(BBZ30P080FMC)	
	11	AZN1366	Bonnet case		33	AZW1024	AF sub assembly
	12	AZN1370	Strain relief bushing				
\triangle	13	AZN1390	AC power cord				
		(ADG-041)					
	14	AZB1111	Nut		101		Earth terminal
		(ABN-093)			102		Side frame
	15	AZB1112	Washer		103		Panel stay
					104		Bottom plate
	16	AZB1109	Nut boss		105		Rear panel
	17	AZN1384	Indicator lens				
\triangle	18	AZT1028	Power transformer		106		LED assembly
	19	AZB1110	Nut		107		Volume assembly
		(NK70FUC)			108		Headphone jack assembly
	20	AZB1113	Screw 3 x 8		109		Power switch assembly
		(BBZ30P080FZK)			110		Heat sink brket
	21	AZB1114	Screw 3 x 8				
		(VBZ30P080FZK)					
	22	AZB1115	Screw 4 x 8				
		(VBZ40P080FMC)					
	23	AZB1116	Screw 3 x 8				
		(VBZ30P080FMC)					
	24	AZB1117	Screw 3 x 8				
		(PMZ30P080FMC)					
\triangle $\star\star$	25	AZC1035	Line across capacitor (C108) (0.01/400V)				

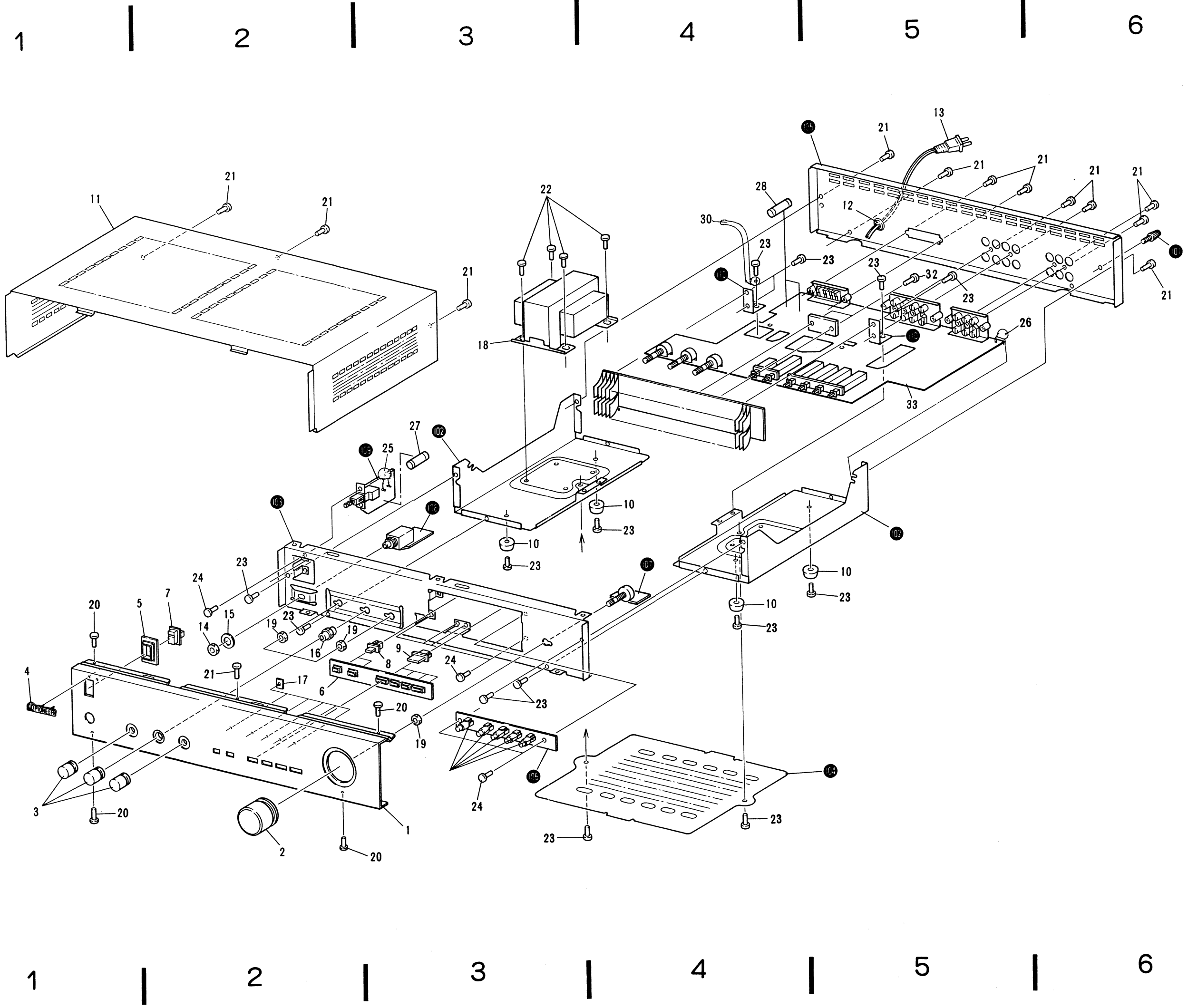

2. P.C.BOARDS CONNECTION DIAGRAM

A

A

AF SUB ASSEMBLY AZW1024

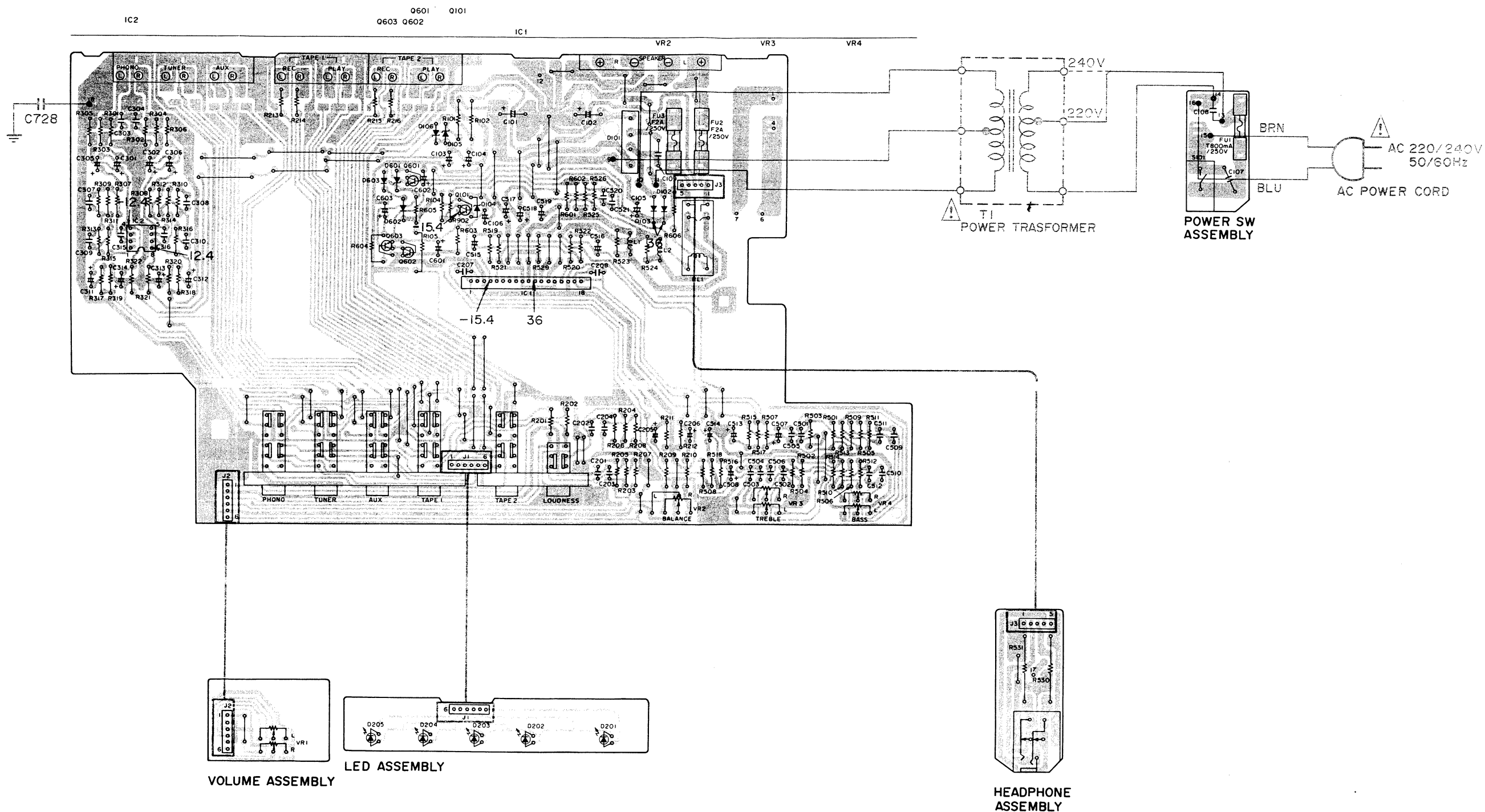

B

B

C

C

D

D

3. SCHEMATIC DIAGRAM

NOTE:
The indicated semiconductors are representative ones only. Other alternative semiconductors may be used and are listed in the parts list.

External Appearance of Transistors and ICs

STK4142 II
STK4141 II

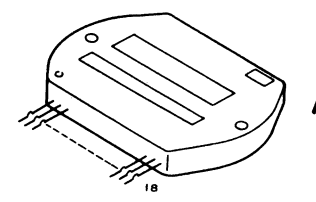

MC4558C
UPC4558D

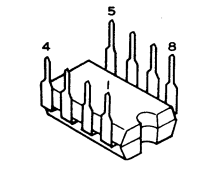

2SA933S

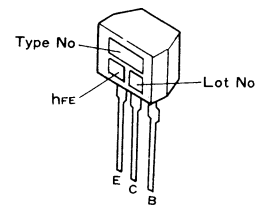

2SC3245

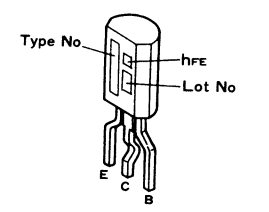

2SC1740S

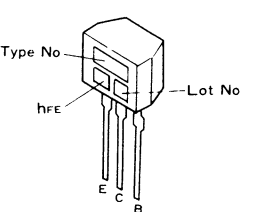

KTC1627A

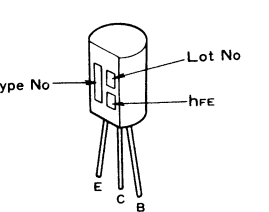

KTC1815Y
KTA970GR

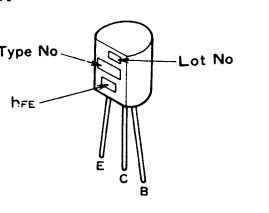

A
B
C
D

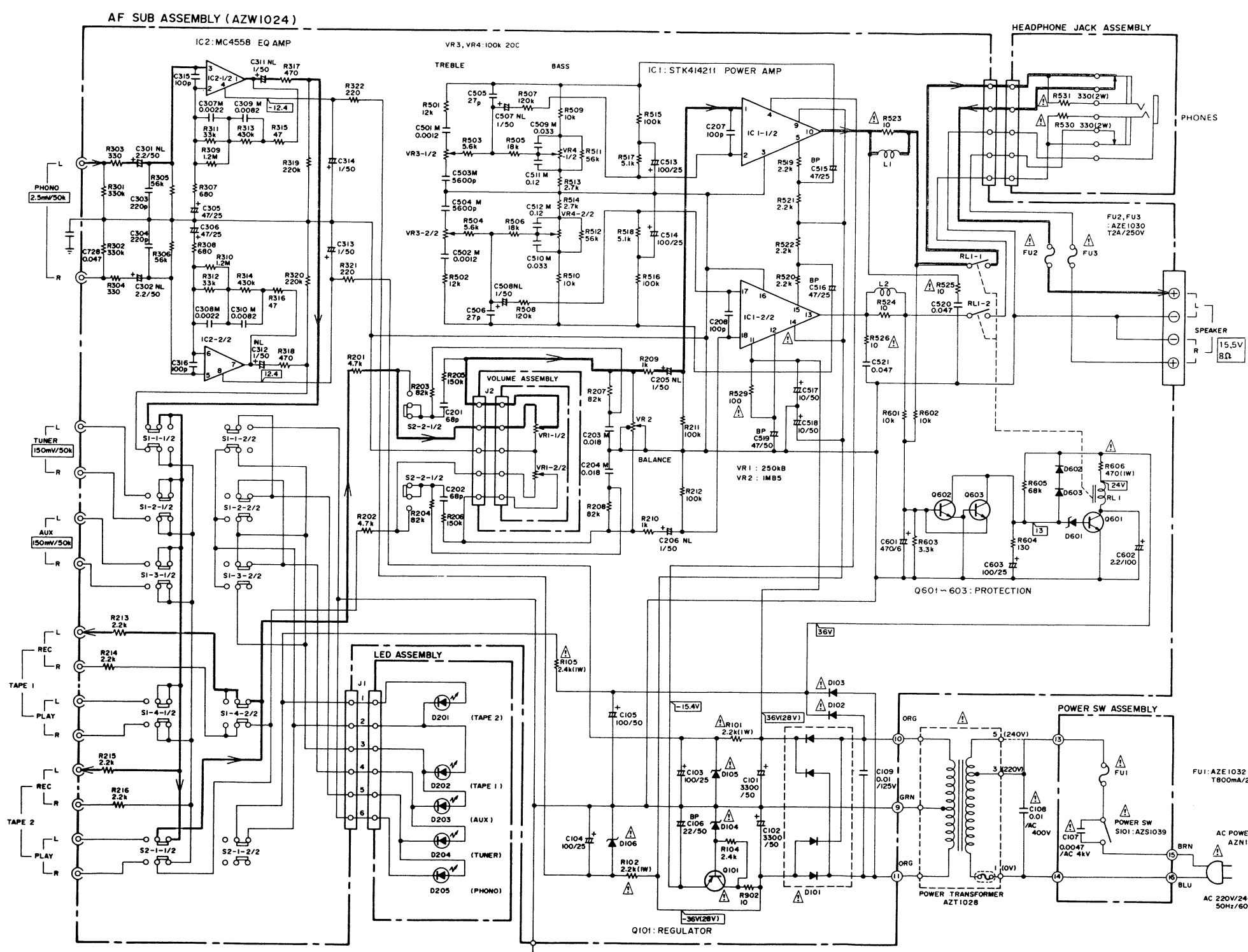

- RESISTORS:**
Indicated in Ω, kΩ, MΩ, 1/5W, 1/10W, 5% tolerance unless otherwise noted k: kΩ, M: MΩ, (F): ±1%, (G): ±2%, (K): ±10%, (M): ±20% tolerance
 - CAPACITORS:**
Indicated in capacity (μF)/voltage (V) unless otherwise noted p: pF
Indication without voltage is 50V except electrolytic capacitor.
 - VOLTAGE, CURRENT:**
⊖: Signal voltage at (30W + 30W/8 ohm) out (1kHz)
⊕: DC voltage (V) at no input signal
Value in () is DC voltage at rated power.
⊖: mA: DC current at no input signal
 - OTHERS:**
→: Signal route
⊗: Adjusting point
The ⊗ mark found on some component parts indicates the importance of the safety factor of the part. Therefore, when replacing, be sure to use parts of identical designation.
⊗: marked capacitors and resistors have parts numbers.
- This is the basic schematic diagram, but the actual circuit may vary due to improvements in design.
- SWITCHES**
- S 1-1 FUNCTION (PHONO) ON-OFF
 - S 1-2 FUNCTION (TUNER) ON-OFF
 - S 1-3 FUNCTION (AUX) ON-OFF
 - S 1-4 FUNCTION (TAPE 1) ON-OFF
 - S 2-1 TAPE 2 ON-OFF
 - S 2-2 LOUDNESS ON-OFF
- The underlined indication the switch position

IC1	STK4142 II (STK4141 III)
IC2	MC4558C (UPC4558D)
Q101	KTA970GR (2SA933S)
Q601	KTC1627A (2SC3245)
Q602, Q603	KTC1815Y (2SC1740S)
D101	RS403L (4D4844)
D102, D103	IN4003 (11E2)
D104	IN966 (RD16E8)
D105, D106, D601	IN964 (RD13E8)
D602, D603	IS2473
D201-D205	AZA1066
L1, 2	AZT1027 (ATH-133)

COILS

Mark	Symbol & Description	Part No.
	L1, L2 Chork coil (1 μ H)	AZT1027 (ATH-133)

CAPACITORS

Mark	Symbol & Description	Part No.
Δ	C101, C102 (3300 μ F/50V)	AZC1038 (ACH1017)
	C103, C104, C513, C514, C603 C105 C106 C109	CEAS101M25 CEAS101M50 CEAS220M50 AZC1034
	C201, C202 C203, C204 C205, C206, C311, C312, C507, C508 C207, C208, C315, C316 C301, C302	CCDSL680J50 CQMA183K50 CEANL010M50 CCDSL101J50 CEANL2R2M50
	C303, C304 C305, C306 C307, C308 C309, C310 C313, C314	CCDSL221J50 CEAS470M25 CQMA222K50 CQMA822K50 CEAS010M50
	C501, C502 C503, C504 C505, C506 C509, C510 C511, C512	CQMA122K50 CQMA562K50 CCDSL270J50 CQMA333K50 CQMA124K50
	C515, C516 C517, C518 C519 C520, C521 C601 C602	CEANP470M25 CEAS100M50 CEANP470M50 CKDYF473Z50 CEAS471M6 CEAS2R2M100

RESISTORS

Mark	Symbol & Description	Part No.
\star	VR2 Variable resistor (BAL)	AZC1032
\star	VR3, VR4 Variable resistor (BASS, TREBLE)	AZC1031
Δ	R101, R102	RS1LMF222J
Δ	R105	RS1LMF242J
Δ	R606	RS1LMF471J
Δ	R523—R526, R902	RD1/4PMFL100J
Δ	R529	RD1/4PMFL101J
	Other resistors	RD1/4PM $\square\square\square$ J

OTHERS

Mark	Symbol & Description	Part No.
	Push terminal (SPEAKERS)	AZK1048
	Ceramic pipe	AZE1034

LED Assembly

SEMICONDUCTORS

Mark	Symbol & Description	Part No.
\star	D201—D205	AZA1066

OTHERS

Mark	Symbol & Description	Part No.
	LED holder	AZN1363

Headphone Jack Assembly

RESISTORS

Mark	Symbol & Description	Part No.
Δ	R530, R531	RS2LF331J

OTHER

Mark	Symbol & Description	Part No.
	Headphone jack (PHONES)	AZK1045 (AKN-058)

Volume Assembly

RESISTOR

Mark	Symbol & Description	Part No.
\star	VR1 Volume Variable resistor	AZC1030

Power Switch Assembly

SWITCH

Mark	Symbol & Description	Part No.
Δ $\star\star$	S101 Push switch (POWER)	AZS1039

CAPACITOR

Mark	Symbol & Description	Part No.
Δ	C107 Line across capacitor (0.0047/AC4kV)	AZC1033

5. PACKING

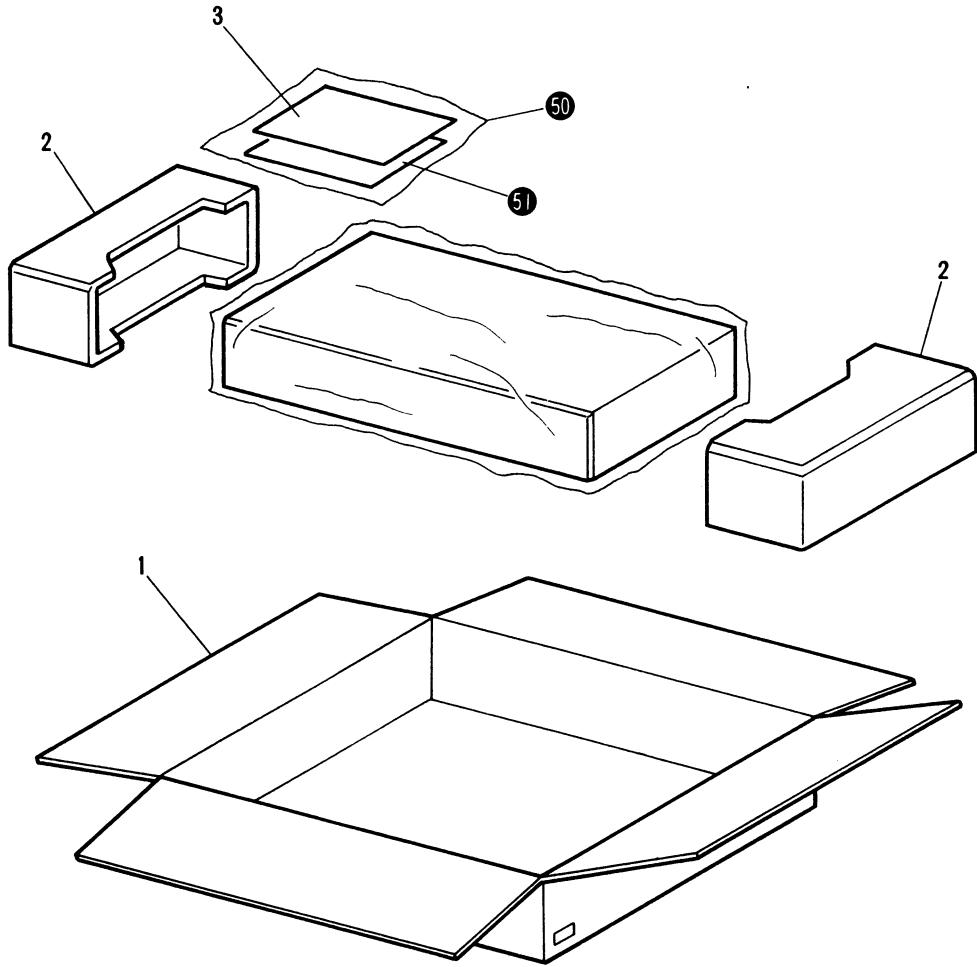

Parts List of Packing

Mark	No.	Part No.	Description
	1	AZH1026	Packing case
	2	AZH1029	Side pad
	3	AZQ1011	Operating instructions
	50		Catalog bag
	51		Warranty card

6. FOR HB AND HEZ TYPES

CONTRAST OF MISCELLANEOUS PARTS

The A-110/HB and HEZ types is the same as the A-110/HE type with the exception of the following sections:

Mark	Symbol & Description	Part No.			Remarks
		A-110/ HE type	A-110/ HB type	A-110/ HEZ type	
	AF sub assembly	AZW1024	AZW1024	AZW1030	
	Headphone jack assembly	Non supply	Non supply	Non supply	
⚠ ★★	Fuse (800mA/250V)	AZE1032	AZE1032	
⚠ ★★	Fuse (630mA/250V)	AZE1031	
⚠	C108 Line across capacitor (0.01/400V)	AZC1035	AZC1035	
	C728 Capacitor	CKDYF473Z50	CKDYF473Z50	
	R709, R710 Carbon F resistor	RD1/4PM100J	
	C729 Ceramic capacitor	CKDYF223Z50	
	Operating instructions (English/German/French/Italian)	AZQ1011	
	Operating instructions (English)	AZQ1008	
	Operating instructions (German)	AZQ1012	
	Side pad	AZH1029	AZH1028	AZH1029	
⚠	AC power cord	AZN1390	AZN1383	AZN1390	
	Power switch assembly*	Non supply	Non supply	Non supply	

* Marked P.C. board assemblies:

Regard less differences on parts numbers, the P.C. board assemblies for the additional types are identical with the HE type.

AF SUB ASSEMBLY (AWZ1030)

The AF Sub assembly (AWZ1030) is the same as the AF Sub assembly (AWZ1024) with the exception of the following sections.

Mark	Symbol & Description	Part No.		Remarks
		AWZ1024	AWZ1030	
	R303, R304 Carbon resistor	RD1/4PM331J	RD1/4PM221J	
	R701-R708 Carbon resistor	RD1/8PM331J	
⚠	C108 Line across capacitor (0.01/400V)	AZC1035	
	C723, C724 Ceramic capacitor	CKDYB472J50	
	C315, C316, C701-C722	CKDYB331J50	

HEADPHONE JACK ASSEMBLY

The Headphone Jack assembly HEZ type is the same as the Headphone Jack assembly HE and HB type with the exception of following sections:

Mark	Symbol & Description	Part No.			Remarks
		HE type	HB type	HEZ type	
	C725-C727 Ceramic capacitor	CKDYB472K50	

7. P.C. BOARD PATTERNS (For HEZ type)

AF SUB ASSEMBLY (AZW1030)

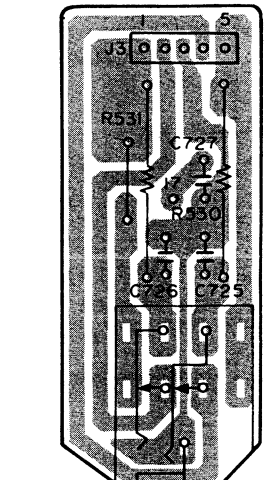
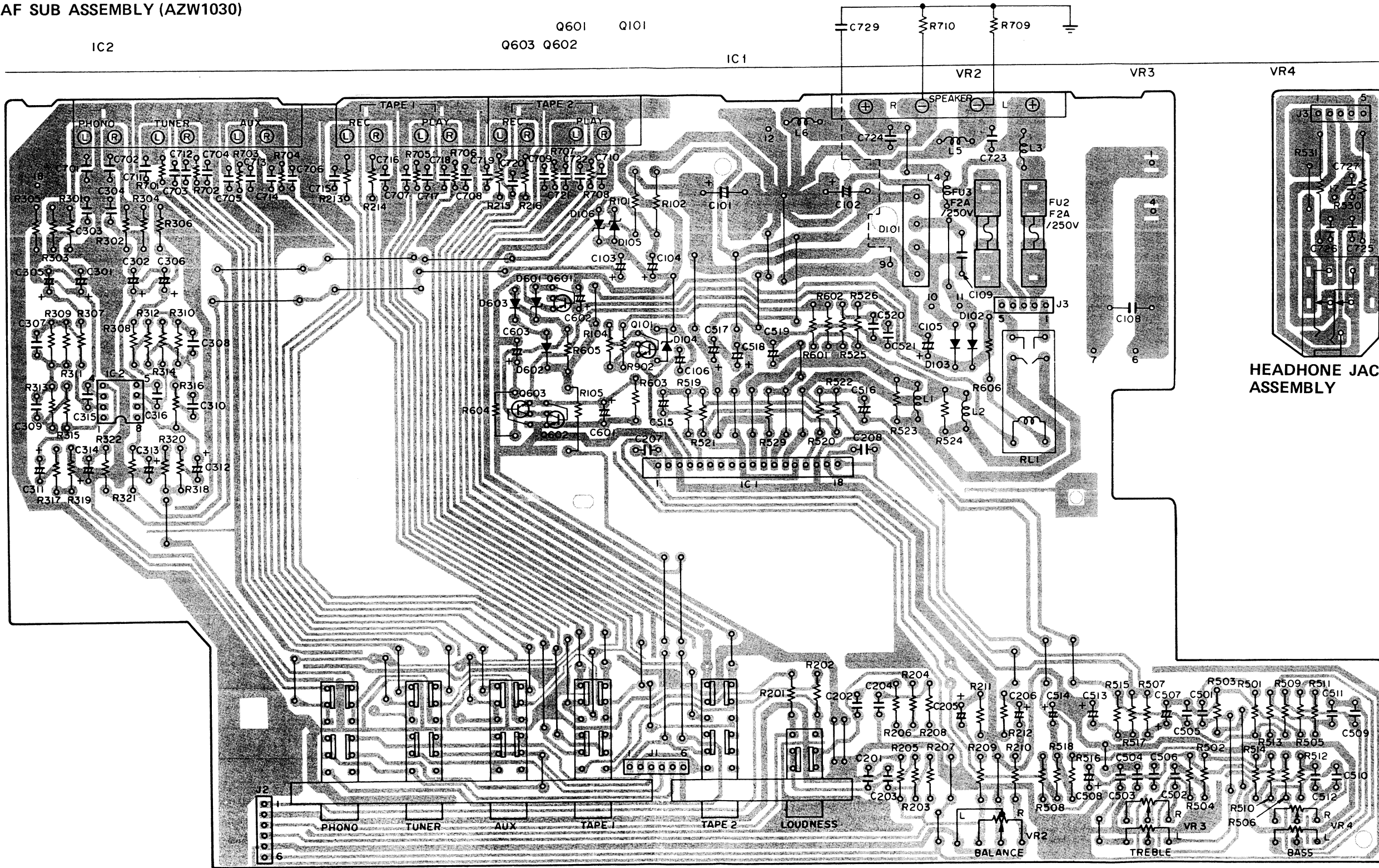

A
B
C
D

A
B
C
D

1 2 3 4 5 6

8. SCHEMATIC DIAGRAMS

• For HEZ type

NOTE:
 The indicated semiconductors are representative ones only.
 Other alternative semiconductors may be used and are listed in the parts list.

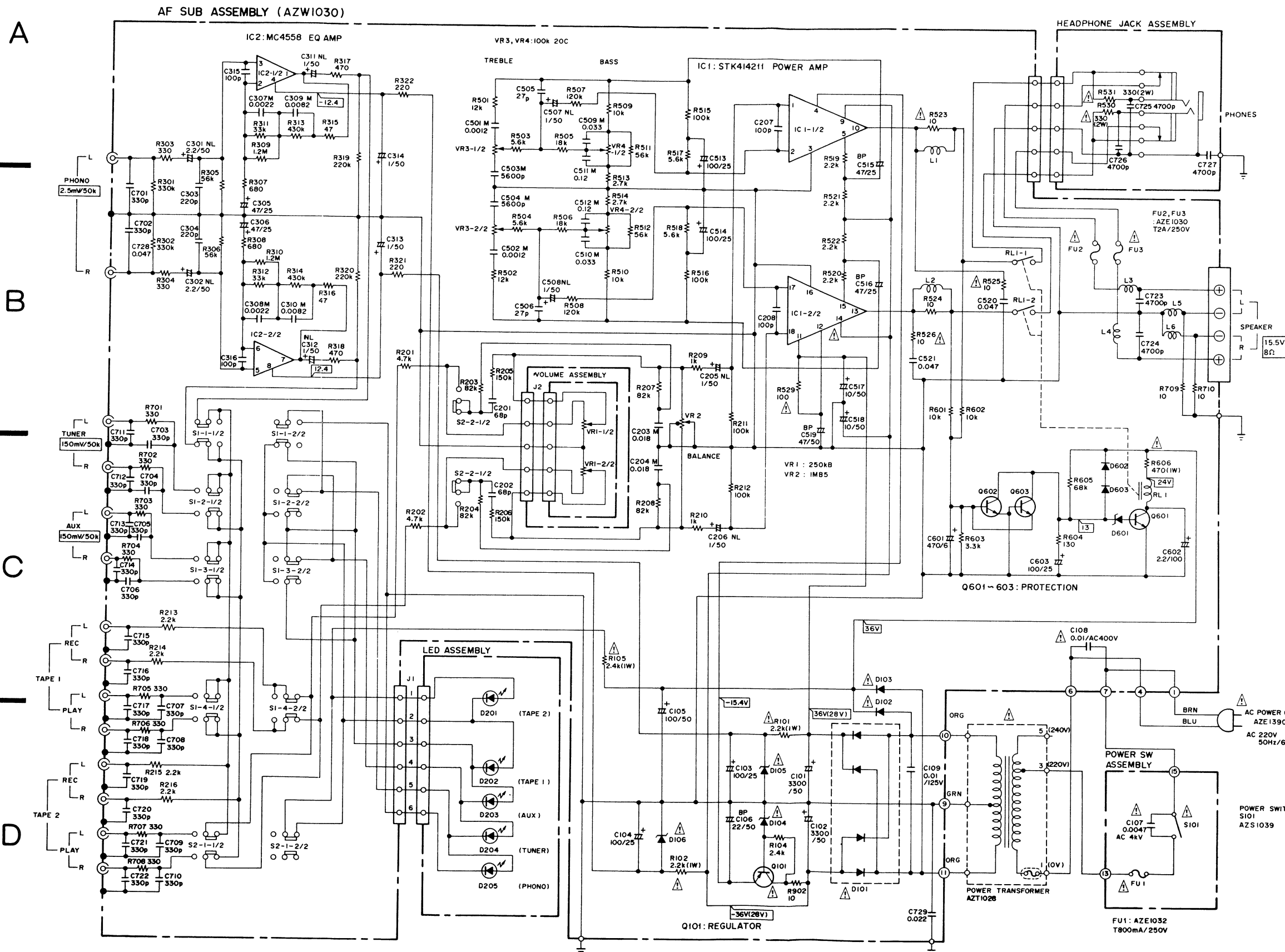

- 1. RESISTORS:**
 Indicated in Ω, ¼W, ½W, ±5% tolerance unless otherwise noted k: kΩ, M: MΩ, (F): ±1%, (G): ±2%, (K): ±10% (M): ±20% tolerance
- 2. CAPACITORS:**
 Indicated in capacity (μF)/voltage (V) unless otherwise noted p: pF Indication without voltage is 50V except electrolytic capacitor.
- 3. VOLTAGE, CURRENT:**
 □: Signal voltage at (30W + 30W/8 ohm) out (1kHz)
 ⊖: DC voltage (V) at no input signal
 Value in () is DC voltage at rated power.
 ⇐ mA: DC current at no input signal
- 4. OTHERS:**
 →: Signal route.
 ⊙: Adjusting point.
 The Δ mark found on some component parts indicates the importance of the safety factor of the part. Therefore, when replacing, be sure to use parts of identical designation.
 * marked capacitors and resistors have parts numbers.
- This is the basic schematic diagram, but the actual circuit may vary due to improvements in design.
- SWITCHES**
- | | | |
|-------|-------------------|--------|
| S 1-1 | FUNCTION (PHONO) | ON-OFF |
| S 1-2 | FUNCTION (TUNER) | ON-OFF |
| S 1-3 | FUNCTION (AUX) | ON-OFF |
| S 1-4 | FUNCTION (TAPE 1) | ON-OFF |
| S 2-1 | TAPE 2 | ON-OFF |
| S 2-2 | LOUDNESS | ON-OFF |
- The underlined indication the switch position

IC1	STK4142 II (STK4141 III)
IC2	MC4558C (UPC4558D)
Q101	KTA970GR (2SA933S) KTC1627A (2SC3245) KTC1815Y (2SC1740S)
Q601, Q602, Q603	KTA970GR (2SA933S) KTC1627A (2SC3245) KTC1815Y (2SC1740S)
D101, D102, D103	RS403L (4D4B44) IN4003 (11E2) IN966 (RD16EB)
D104, D105, D106, D601	IN964 (RD13EB) IS2473
D602, D603	IS2473
D201-D205	AZA1066
L1,2	ATZ1027 (ATH-133)

• For HB type

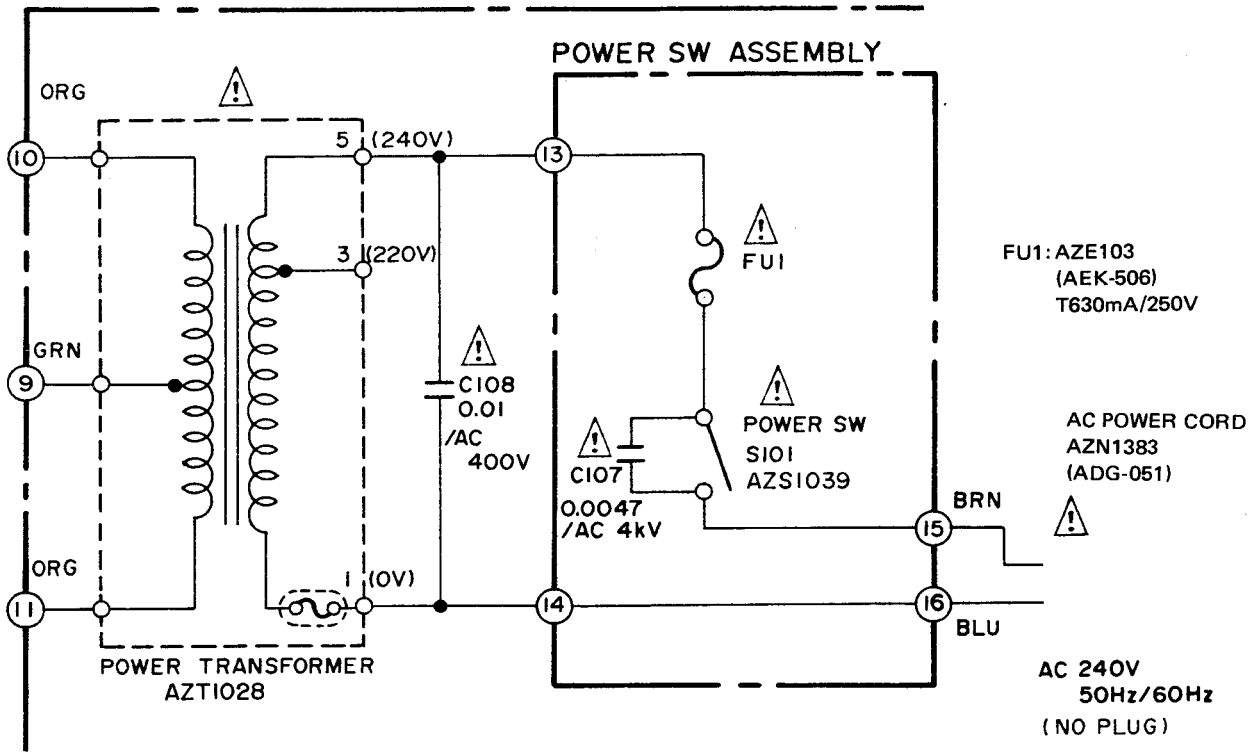

LINE VOLTAGE SELECTION

Line voltage can be changed with the following steps.

1. Disconnect the AC power cord.
2. Remove the top cover.
3. Change the connection of the power transformer primary taps.
4. Stick the line voltage label on the rear panel.

Part No.	Description
AAX-193	220V label
AAX-192	240V label

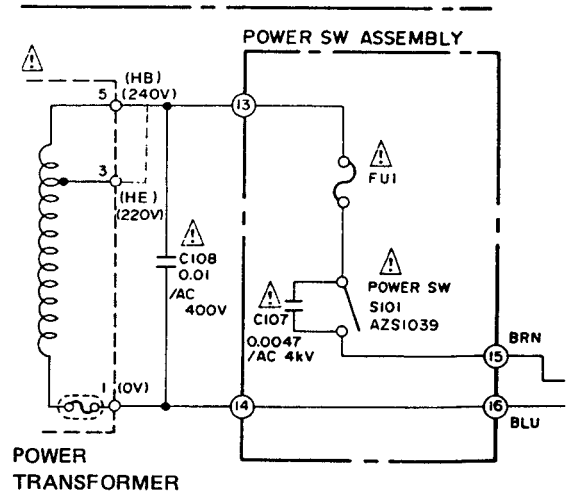

9. SPECIFICATIONS

Amplifier Section

- Continuous average power output (both channels driven)
30 Hz ~ 20kHz
(T.H.D. 0.2%, 8 Ω) 25 W + 25 W
1kHz
(T.H.D. 1%, 8 Ω , DIN) 30 W + 30 W
- Total harmonic distortion
(30 Hz ~ 20 kHz, 8 Ω , AUX) 0.2%
- Input sensitivity/impedance
PHONO 2.5 mV/50 K Ω
TUNER, AUX, TAPE 1, TAPE 2 150 mV/50 K Ω
- Output level impedance
TAPE REC, TAPE 2/ADAPTOR OUT 150 mV
SPEAKER 8 Ω
- Frequency response
PHONO
(RIAA EQUALIZATION) 30 Hz ~ 20 kHz \pm 1.5 dB
TUNER, CD/AUX, TAPE PLAY, TAPE 2/ADAPTOR
. 10 Hz ~ 50 kHz \pm 3 dB
- TONE control
BASS \pm 10 dB (100 Hz)
TREBLE \pm 10 dB (10 kHz)
- LOUDNESS control
(VOLUME control set at -40 dB position)
. +6 dB (100 Hz), +3dB (10 kHz)
- Hum and noise (IHF, shorted circuit A NETWORK)
PHONO 70 dB
TUNER, CD/AUX, TAPE PLAY, TAPE 2/ADAPTOR
. 95 dB

Power supply & miscellaneous

- Power requirements AC 220 V/240 V,
50 Hz/60 Hz
- Power consumption 170 W
- Dimensions 420 (W) x 98 (H) x 200 (D) mm
16 (W) x 3-3/4 (H) x 9-3/4 (D) in.
- Weight (net) 4.5 kg (9 lb 15 oz)

Accessories

- Operating instructions 1
- *Specifications and design subject to possible modification
without notice due to improvements.*

10. FRONT PANEL FACILITIES

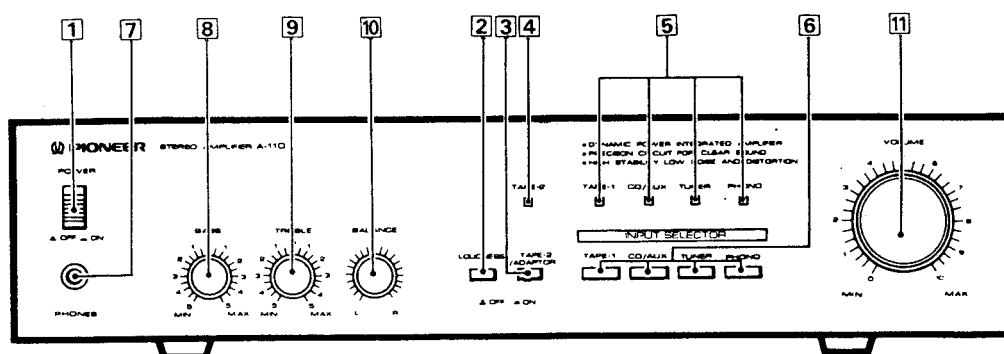

1 POWER switch

Press to turn power to the unit ON and OFF.

2 LOUDNESS switch

Press to activate the loudness function when listening to music at a low volume: the low and high tones will be emphasized to render sounds rich in power and fullness even at low volume levels.

3 TAPE 2/ADAPTOR switch

Press when using a second tape deck or other adaptor equipment, such as a graphic equalizer, that has been connected to the unit by means of the TAPE 2/ADAPTOR terminals on the rear panel.

4 TAPE 2/ADAPTOR indicator

Illuminates when the TAPE 2/ADAPTOR switch is ON.

5 Function indicators

Illuminate to show which function is currently active, i.e. which function switch has been pressed.

NOTE:

The TAPE 1 indicator will illuminate when none of the INPUT SELECTOR switches has been pressed.

6 INPUT SELECTOR switches

- PHONO: Press when you want to listen to records on a turntable.
- TUNER: Press when you want to listen to AM or FM radio broadcasts with a tuner.
- CD/AUX: Press when you want to listen to the sound from a CD player or other component, such as a TV, connected to the CD/AUX terminal.
- TAPE 1: Press when you want to listen to tape playback from a tape deck.

7 PHONES jack

When using headphones, insert their plug into this jack.

NOTE:

Don't forget to turn the volume down before listening to headphones: turning the volume up too high can result in serious damage to your ears.

8 BASS tone control

Use to adjust low frequency range tones. The center position is the flat (normal) position. Rotating this knob to the right will cause low-frequency tones to be emphasized, while rotating it to the left will cause them to be suppressed.

9 TREBLE tone control

Use to adjust high frequency range tones. The center position is the flat (normal) position. Rotating this knob to the right will cause high-frequency tones to be emphasized, while rotating it to the left will cause them to be suppressed.

10 BALANCE control

Use to adjust the volume balance between the left and right speaker channels. This knob should normally be left in the center position and is generally used only when the sound from one speaker is louder than the sound from the other. In such cases, turn the knob in the opposite direction of the louder speaker to achieve uniform volume from both speakers.

11 VOLUME control

Use to adjust the volume level; rotating it clockwise increases the volume. No sound will be emitted when set to the "0" position, and maximum volume will be output when set to the "10" position.